

Service Manual

PIONEER
The Art of Entertainment

103.

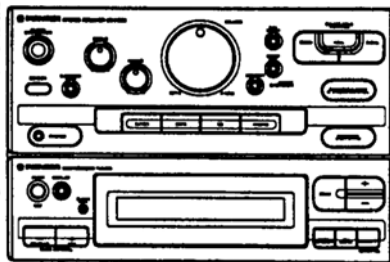

ORDER NO.
ARP2452

STEREO RECEIVER

SX-P520

SX - P520 HAS THE FOLLOWING :

Type	Power Requirement	Remarks
HE	AC220V - 230V, 240V (Switchable) *	
HB	AC220V - 230V, 230 - 240V (Switchable) *	
HEWZI	AC220V - 230V; 230 - 240V (Switchable) *	
KUC	AC120V only	
SD	AC110V, 120 - 127V, 220V, 240V (Switchable)	
YPW	AC240V only	

* Change the connection of the transformer's primary wiring.

- This manual is applicable to SX - P520/HE, HB and HEWZI.
- For HB and HEWZI types, refer to pages 45 - 50.
- For the other types, refer to the applicable service manuals.
- These products are component of systems. For the system composition, refer to the system manual (s).
- Ce manuel pour le service comprend les explications de réglage en français.
- Este manual de servicio trata del método ajuste escrito en español.

CONTENTS

1. SAFETY INFORMATION	2	6. ADJUSTMENTS	40
2. SPECIFICATIONS	3	6. REGLAGE	41
3. EXPLODED VIEWS, PACKING AND PARTS LIST	4	6. AJUSTE	42
4. SCHEMATIC DIAGRAMS AND PCB CONNECTION DIAGRAMS	8	7. IC INFORMATION	43
5. PCB PARTS LIST	36	8. FOR HB AND HEWZI TYPES	45
		9. PANEL FACILITIES	51

PIONEER ELECTRONIC CORPORATION 4-1, Meguro 1-Chome, Meguro-ku, Tokyo 153, Japan
PIONEER ELECTRONICS SERVICE INC. P.O. Box 1760, Long Beach, California 90801 U.S.A..
PIONEER ELECTRONICS OF CANADA, INC. 300 Allstate Parkway Markham, Ontario L3R 0P2 Canada
PIONEER ELECTRONIC [EUROPE] N.V. Haven 1087 Keetberglaan 1, 9120 Melsele, Belgium
PIONEER ELECTRONICS AUSTRALIA PTY. LTD. 178-184 Boundary Road, Braeside, Victoria 3195, Australia TEL: [03] 580-9911
 © PIONEER ELECTRONIC CORPORATION 1992

DEF RFR 1002 Printed in Japan

This service manual is intended for qualified service technicians; it is not meant for the casual do-it-yourselfer. Qualified technicians have the necessary test equipment and tools, and have been trained to properly and safely repair complex products such as those covered by this manual. Improperly performed repairs can adversely affect the safety and reliability of the product and may void the warranty. If you are not qualified to perform the repair of this product properly and safely, you should not risk trying to do so and refer the repair to a qualified service technician.

WARNING

Lead in solder used in this product is listed by the California Health and Welfare agency as a known reproductive toxicant which may cause birth defects or other reproductive harm (California Health & Safety Code, Section 25249.5).

When servicing or handling circuit boards and other components which contain lead in solder, avoid unprotected skin contact with the solder. Also, when soldering do not inhale any smoke or fumes produced.

1. SAFETY INFORMATION

(FOR USA MODEL ONLY)

1. SAFETY PRECAUTIONS

The following check should be performed for the continued protection of the customer and service technician.

LEAKAGE CURRENT CHECK

Measure leakage current to a known earth ground (water pipe, conduit, etc.) by connecting a leakage current tester such as Simpson Model 229-2 or equivalent between the earth ground and all exposed metal parts of the appliance (input/output terminals, screwheads, metal overlays, control shaft, etc.). Plug the AC line cord of the appliance directly into a 120V AC 60Hz outlet and turn the AC power switch on. Any current measured must not exceed 0.5mA.

ANY MEASUREMENTS NOT WITHIN THE LIMITS OUTLINED ABOVE ARE INDICATIVE OF A POTENTIAL SHOCK HAZARD AND MUST BE CORRECTED BEFORE RETURNING THE APPLIANCE TO THE CUSTOMER.

2. PRODUCT SAFETY NOTICE

Many electrical and mechanical parts in the appliance have special safety related characteristics. These are often not evident from visual inspection nor the protection afforded by them necessarily can be obtained by using replacement components rated for voltage, wattage, etc. Replacement parts which have these special safety characteristics are identified in this Service Manual.

Electrical components having such features are identified by marking with a Δ on the schematics and on the parts list in this Service Manual.

The use of a substitute replacement component which does not have the same safety characteristics as the PIONEER recommended replacement one, shown in the parts list in this Service Manual, may create shock, fire, or other hazards.

Product Safety is continuously under review and new instructions are issued from time to time. For the latest information, always consult the current PIONEER Service Manual. A subscription to, or additional copies of, PIONEER Service Manual may be obtained at a nominal charge from PIONEER.

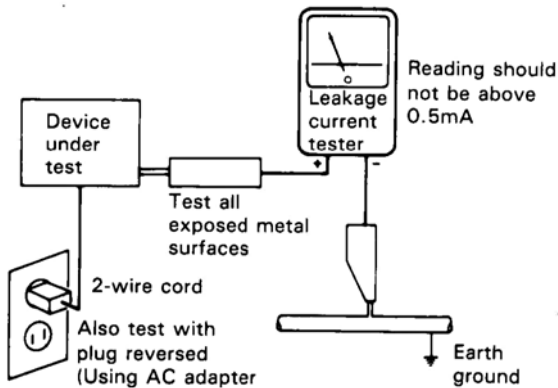

AC Leakage Test

2. SPECIFICATIONS

STEREO RECEIVER: SX-P520

Amplifier Section

Continuous Power Output (DIN)	30 W + 30 W
	(1 kHz, T.H.D. 5%, 8 ohms)
Continuous Power Output (RMS)	35 W + 35 W
	(1 kHz, T.H.D. 5%, 8 ohms)
Music Power (DIN)	48 W + 48 W
	(1 kHz, T.H.D. 10%, 8 ohms)
Total Harmonic Distortion	
(1 kHz, 20 W, 8 ohms)	0.2% *

Miscellaneous

Power Requirements	220 - 230 V AC, 50/60 Hz
Power Consumption	182 W
Dimensions	260 (W) x 180 (H) x 301 (D) mm
Weight (without package)	4.9 kg

FM/AM Tuner Section

FM Tuner Section

Frequency Range	87.5 MHz to 108.0 MHz
Usable Sensitivity	Mono: 12.8 dBf, IHF
	(1.2 μ V/75 ohms)
Sensitivity (DIN)	Mono S/N 26 dB: 1 μ V/75 ohms
	Stereo S/N 46 dB: 50 μ V/75 ohms
Signal-to-Noise Ratio (IHF, 85 dBf Input)	Mono: 77 dB
	Stereo: 73 dB
Signal-to-Noise Ratio (DIN)	Mono: 66 dB
	Stereo: 60 dB
Distortion	Stereo: 0.5 % (1kHz)
Antenna Input	75 ohms unbalanced

AM (MW) Tuner Section

Frequency Range	531 kHz to 1,602 kHz
Sensitivity (IHF, Loop antenna)	350 μ V/m
Antenna	Loop Antenna

LW Tuner Section (For LW equipped models only)

Frequency Range	153 kHz to 281 kHz
Sensitivity (IHF, Loop antenna)	1500 μ V/m
Antenna	Loop Antenna

Accessories

Remote Control Unit	1
Dry Cell Batteries (AAA/R03-UM4)	2
FM T-type Antenna	1
AM Loop Antenna	1
Operating Instructions	1

* Measured by audio spectrum analyzer.

NOTE:

Specifications and design subject to possible modification without notice due to improvements.

3. EXPLODED VIEWS, PACKING AND PARTS LIST

NOTES:

- The parts with an encircled number are generally unavailable because they are not in our Master Spare Parts List.
- The Δ mark found on some component parts indicates the importance of the safety factor of the part. Therefore, when replacing, be sure to use parts of identical designation.
- Parts marked by "⊙" are not always kept in stock. Their delivery time may be longer than usual or they may be unavailable.

Parts list of Exterior and Packing

Mark	No.	Description	Parts No.	Mark	No.	Description	Parts No.
⊙	1	POWER ASSEMBLY	AWZ3944		41	SCREW	CBZ30P080FMC
⊙	2	TRANS ASSEMBLY	AWZ3930		42	NUT	NK90FUC
	3	INSULATOR	AEZ1004		43	FOOT (RUBBER)	REC-434
	4	LOOP ANTENNA (L)	ATB1006		44	SCREW	VBZ30P160FMC
	5	REMOTE CONTROL UNIT (CU-SX040)	AXD1267	Δ	45	FUSE (T800mA, FU1)	AEK-507
				Δ	46	FFC (J)	ADD1100
⊙	6	FRONT ASSEMBLY	AWZ3950	Δ	47	POWER TRANSFORMER	ATS1394
⊙	7	TUNER ASSEMBLY	AWZ3938		48	SPACER	AEC1236
⊙	8	VOLUME ASSEMBLY	AWZ3941		49	OPE. INSTRUCTIONS	ARC1324
⊙	9	HEADPHONE ASSEMBLY	AWZ3942			(Dutch, Swedish, Spanish, Portuguese) RECEIVER	
	10	VOLUME KNOB	AAB1250		50	OPE. INSTRUCTIONS	ARC1337
	11				(Dutch, Swedish, Spanish, Portuguese) CASSETTE, CD	
	12	ROTARY KNOB	AAB1273		51	OPE. INSTRUCTIONS	ARE1223
	13	BAND BUTTON	AAD2177			(English, French, German, Italian) RECEIVER	
	14	FUNCTION BUTTON	AAD2208		52	OPE. INSTRUCTIONS	ARE1233
	15	SFC BUTTON	AAD2179			(English, French, German, Italian) CASSETTE, CD	
	16	WAKE UP BUTTON	AAD2180		53	DRY CELL (R03, "AAA")	AEX-021
	17	TIMER BUTTON	AAD2181		54	SHEET	AHG1040
	18	POWER BUTTON	AAD2183		55	FRONT PAD	AHA1476
	19	AUDITION BUTTON	AAD2185		56	REAR PAD	AHA1477
	20	BATTERY COVER	AZA1375		57	PACKING CASE	AHD2219
	21	TUNER DISPLAY PANEL	AAK2260		58	FM ANTENNA	ADH1005
	22	REMOCON FILTER	AAK2261		59	SCREW	VBZ35P080FMC
	23	FUSE CARD	AAK-243				
	24	SCREW (STEEL)	ABA1095				
Δ	25	AC POWER CORD	ADG1049				
	26	RUBBER SHEET	AEB1111				
Δ	27	STRAIN RELIEF	AEC-882				
	28	NYLON RIVET	AEC1160				
	29	SPACER	AEC1358				
	30	FRONT PANEL	AMB1937				
	31	CHASSIS	ANA1136				
	32	REAR PANEL	ANC1829				
	33	BONNET	ANE1326				
	34	PACK HOLDER	ANG1434				
	35	HEAT SINK HOLDER A	ANG1628				
	36	HEAT SINK HOLDER B	ANG1629				
	37	HEAT SINK	ANH1361				
	38	SCREW	BBZ30P060FMC				
	39	SCREW	BBZ30P080FZK				
	40	SCREW	BPZ26P080FMC				

A

B

C

D

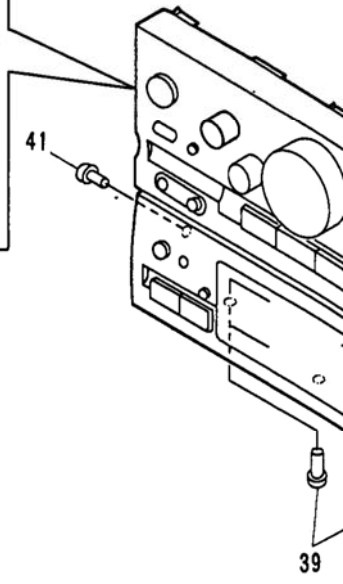
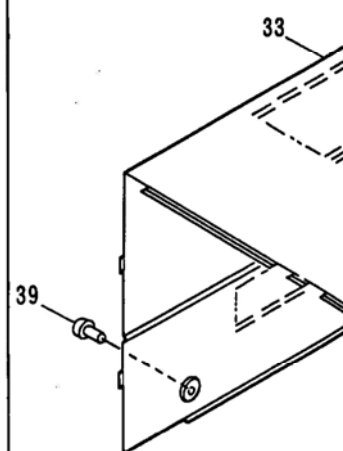
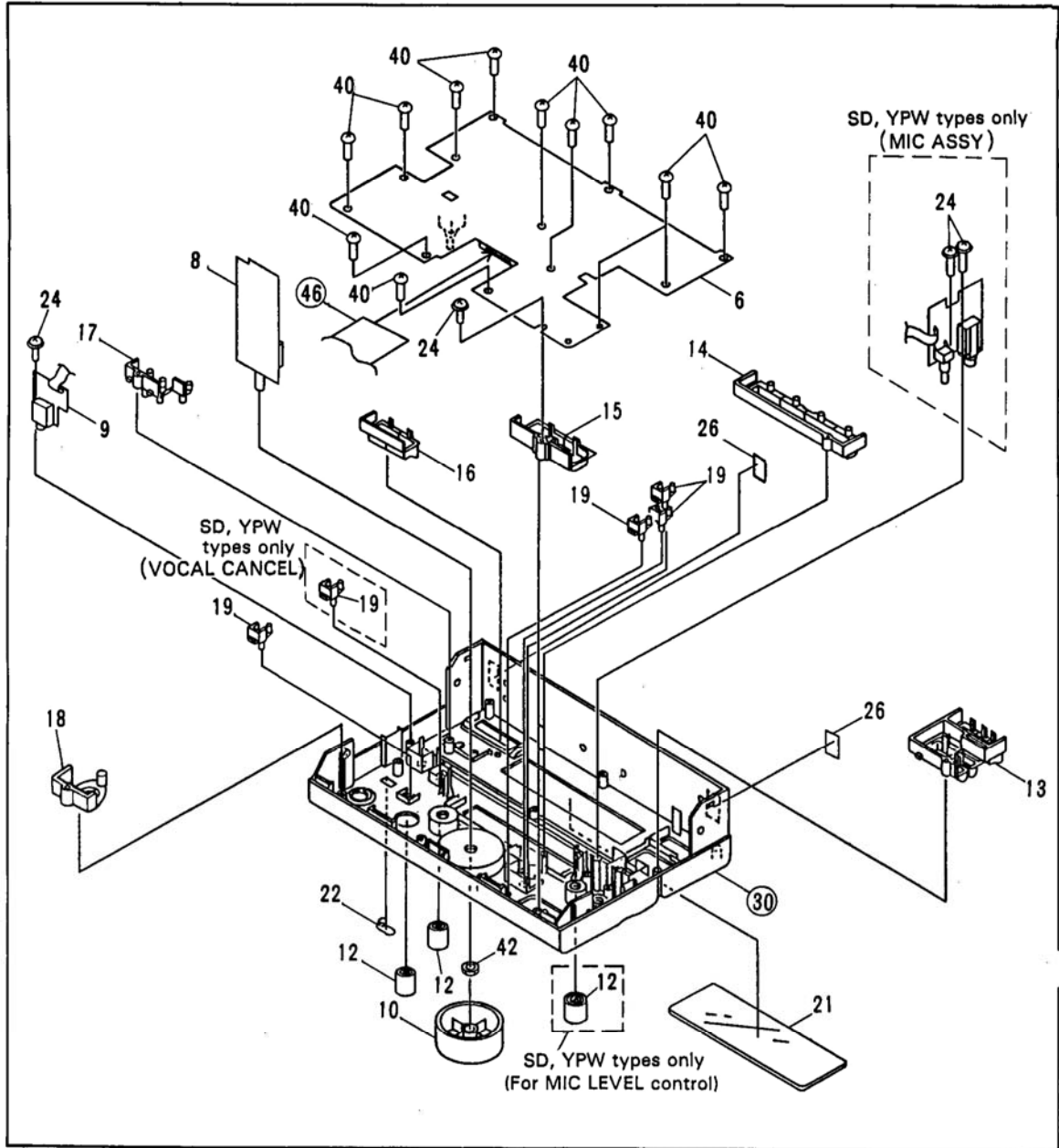

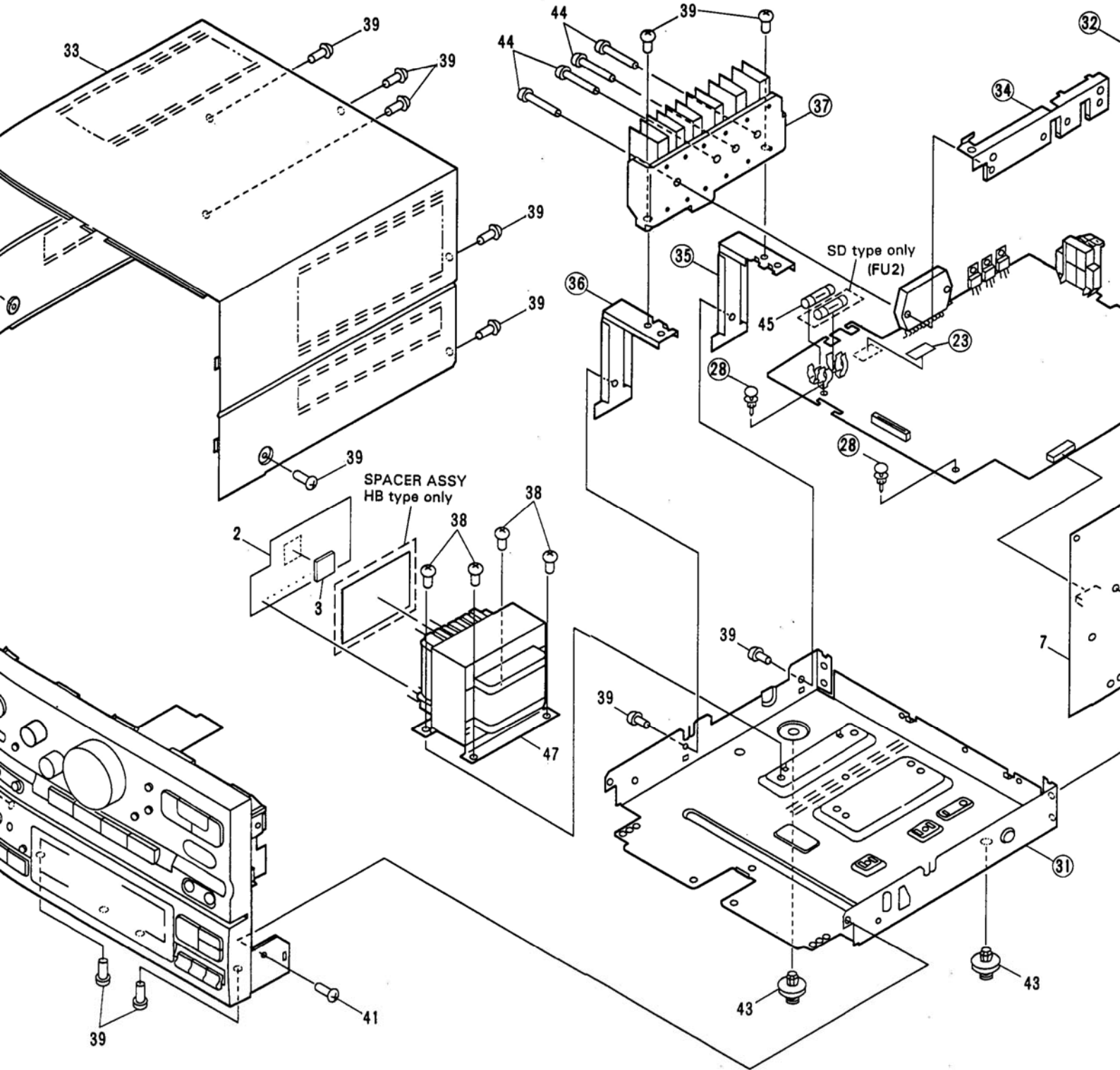

NOTE : Screws adjacent to ▼ mark on the product are used for disassembly.

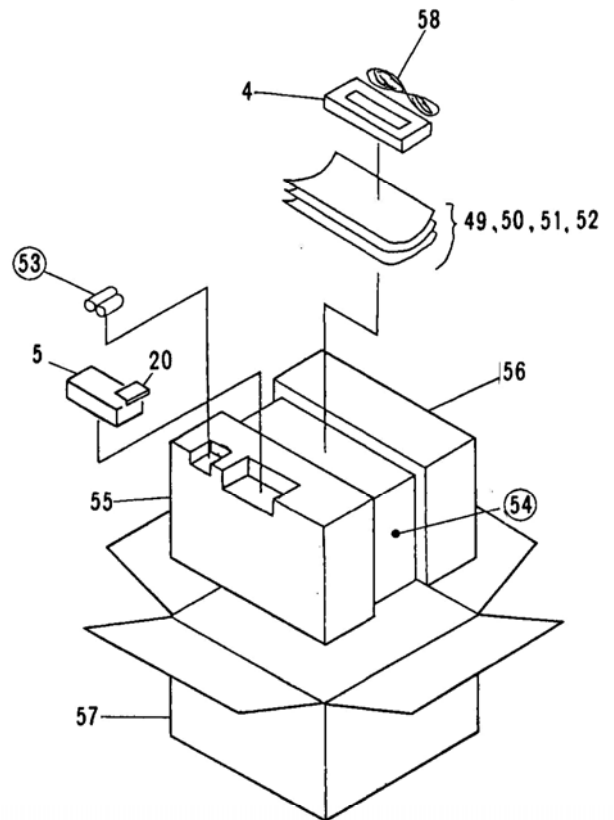
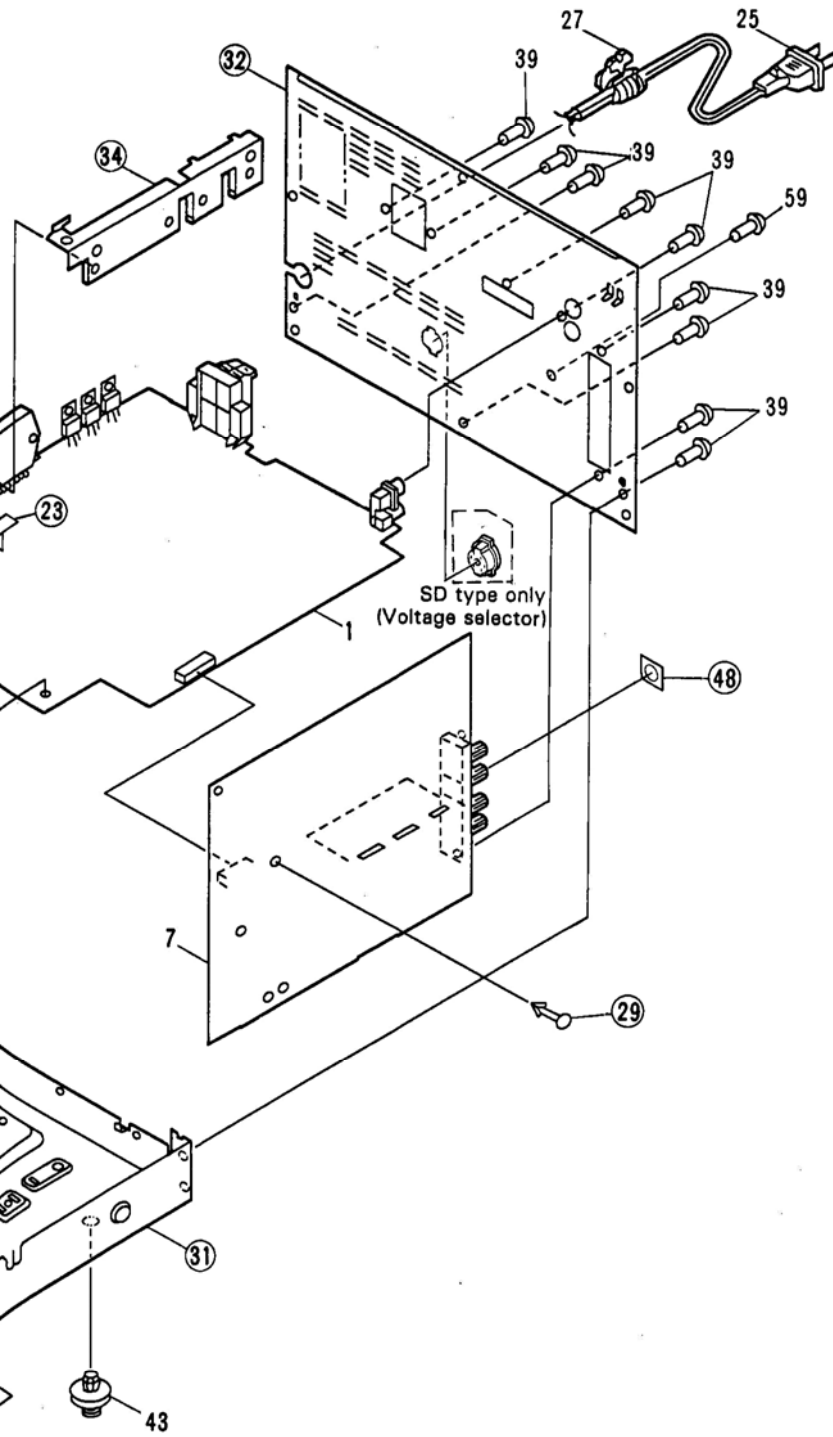

4. SCHEMATIC DIAGRAMS AND PCB CONNECTION DIAGRAMS

4.1 CONNECTION DIAGRAM

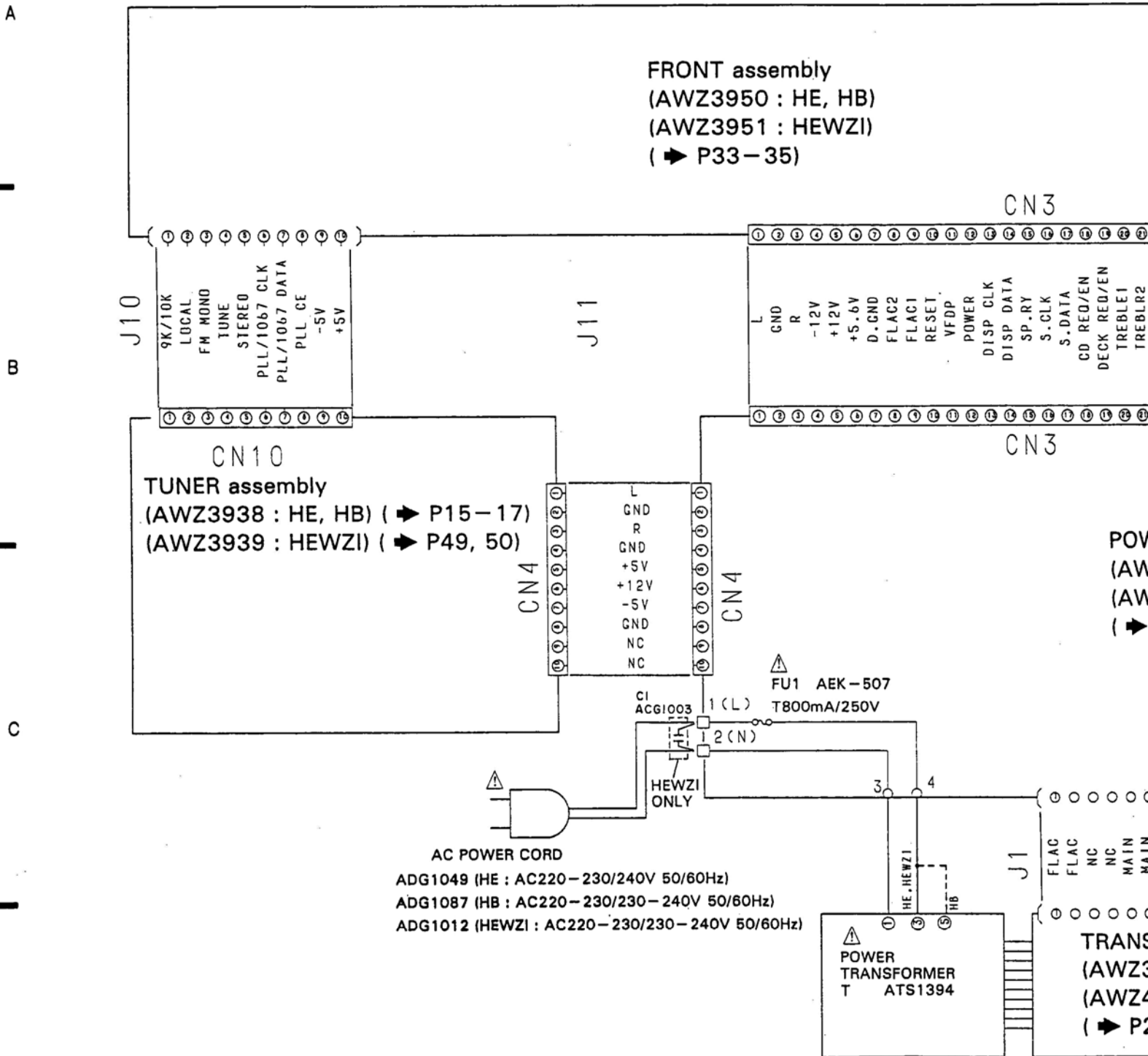

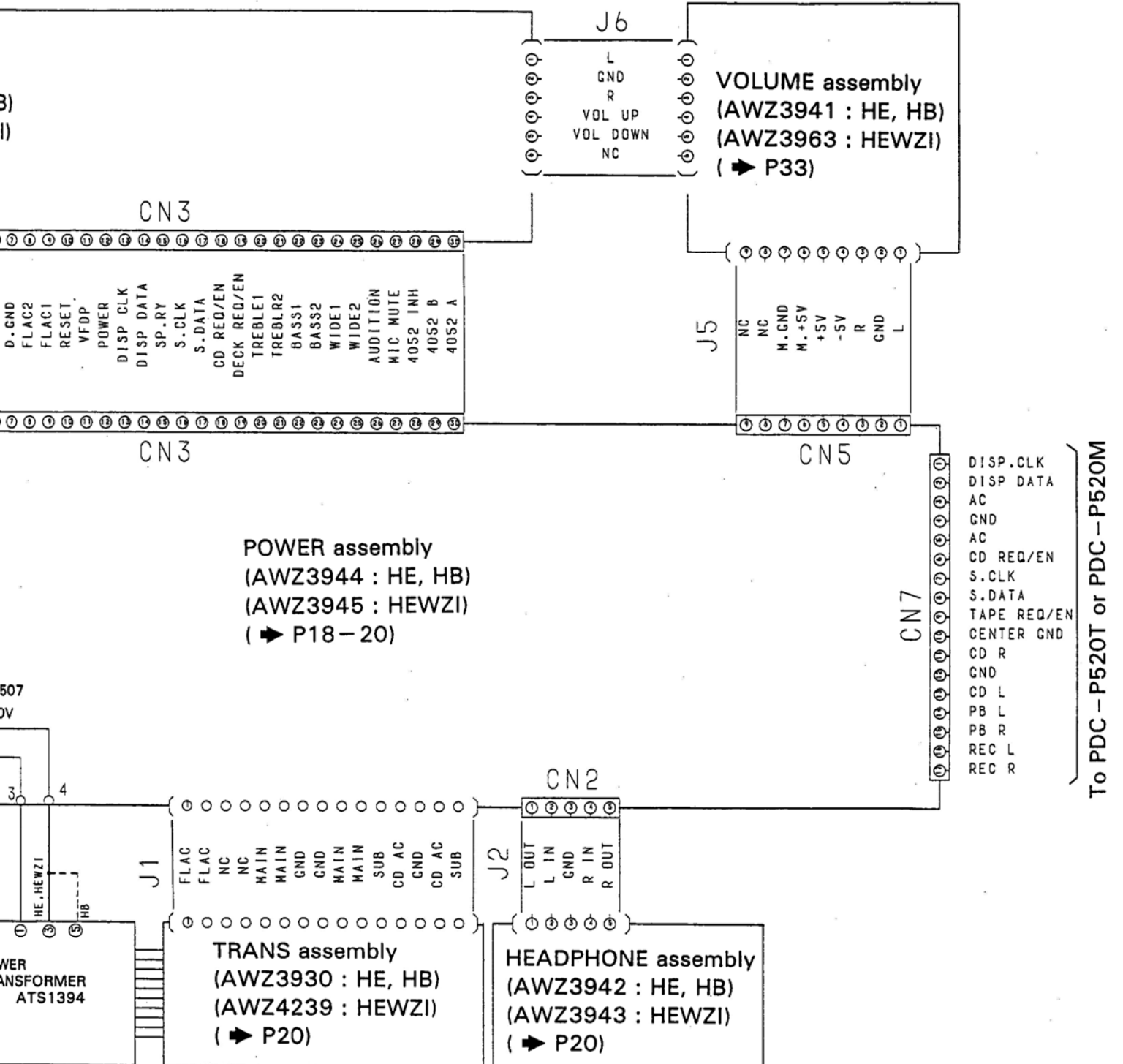

1. RESISTORS:

Indicated in Ω , $\frac{1}{4}W$, $\frac{1}{2}W$, $\pm 5\%$ tolerance unless otherwise noted k: k Ω ,
M: M Ω , (F): $\pm 1\%$, (G): $\pm 2\%$, (K): $\pm 10\%$ (M): $\pm 20\%$ tolerance

A 2. CAPACITORS:

Indicated in capacity (μF)/voltage (V) unless otherwise noted p: pF
Indication without voltage is 50V except electrolytic capacitor.

3. VOLTAGE, CURRENT:

: Signal voltage at (30W + 30W 8 Ω)output (1kHz)

: DC voltage (V) at no input signal

Value in () is DC voltage at rated power.

 mA: DC current at no input signal

mV: Signal voltage at FM 1kHz ± 75 kHz

4. OTHERS:

: Signal route.

: Adjusting point.

The  mark found on some component parts indicates the importance of the safety factor of the part. Therefore, when replacing, be sure to use parts of identical designation.

* marked capacitors and resistors have parts numbers.

 (RED): Measurement point

This is the basic schematic diagram, but the actual circuit may vary due to improvements in design.

B 5. SWITCHES (The underline indicates the switch position)

FRONT assembly

S3001	POWER
S3002	TIMER SET
S3003	WAKE UP / -
S3004	FM MONO
S3005	TUNER -
S3006	SFC BGM
S3007	SMART MEMORY
S3008	SFC CLEAR
S3009	S. STEREO WIDE
S3011	DISPLAY
S3012	REC TIMER / +
S3013	FREQ / ST
S3014	TUNER +
S3015	SFC DISCO
S3016	SMART START / SET
S3017	FUNCTION CD
S3018	FUNCTION TUNER
S3020	CLOCK ADJUST
S3021	MEMORY
S3022	BAND
S3023	SFC HALL
S3024	FUNCTION PHONO
S3025	FUNCTION TAPE

C

D

4.2 TUNER ASSEMBLY

1A (W3338)

A

B

C

D

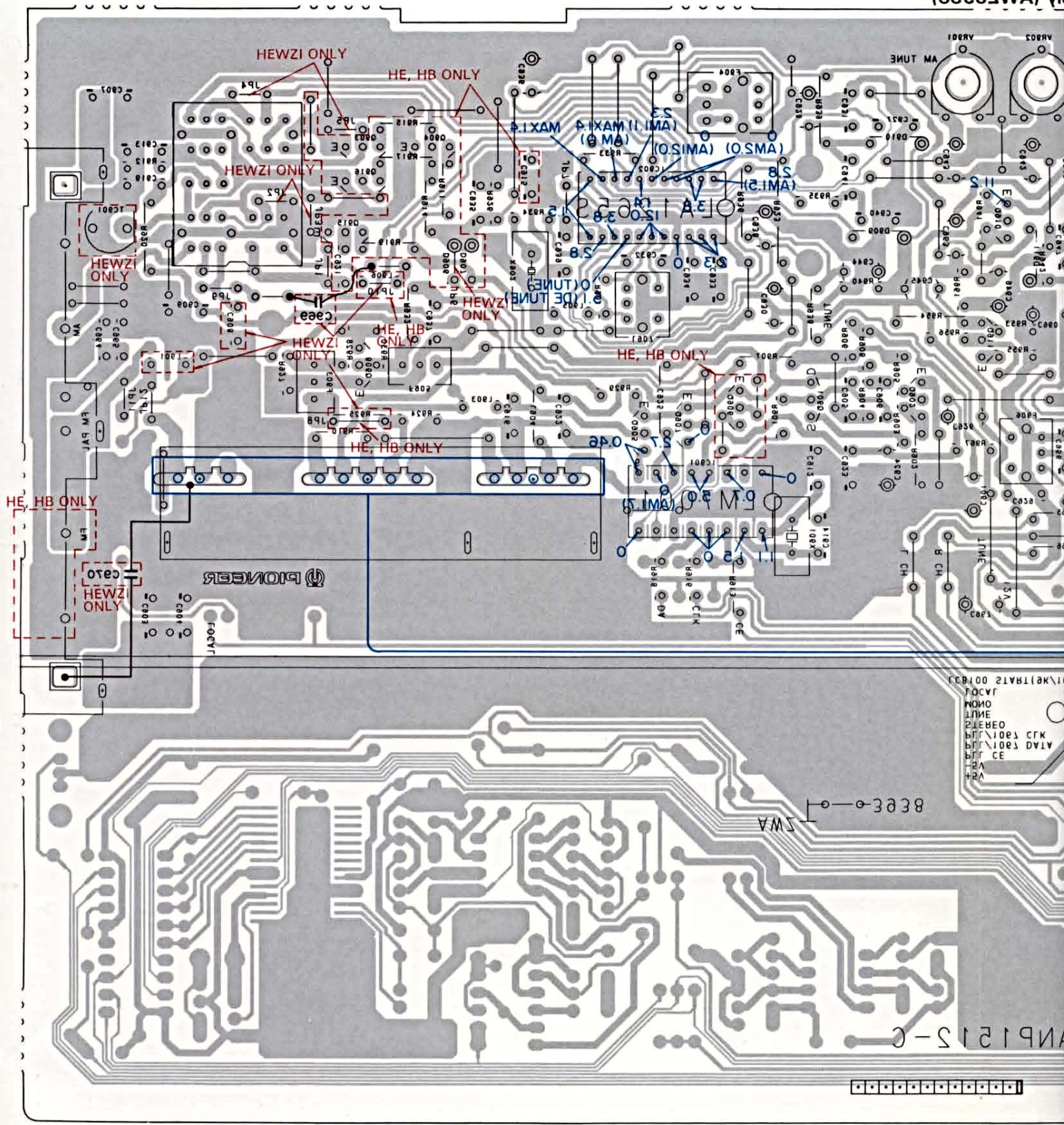

100V VR001
 0010 0011
 0005
 0001
 0002 0003 0004
 0005
 0006
 0007 0008 0009
 0010 0011 0012 0013 0014 0015 0016 0017 0018 0019 0020 0021 0022 0023 0024 0025 0026 0027 0028 0029 0030 0031 0032 0033 0034 0035 0036 0037 0038 0039 0040 0041 0042 0043 0044 0045 0046 0047 0048 0049 0050 0051 0052 0053 0054 0055 0056 0057 0058 0059 0060 0061 0062 0063 0064 0065 0066 0067 0068 0069 0070 0071 0072 0073 0074 0075 0076 0077 0078 0079 0080 0081 0082 0083 0084 0085 0086 0087 0088 0089 0090 0091 0092 0093 0094 0095 0096 0097 0098 0099 0100

e

2

4

This P. C. B connection diagram is viewed from the parts mounted side.

NOTE

1. This P.C.B connection diagram is viewed from the parts mounted side.
2. The parts which have been mounted on the board can be replaced with those shown with the corresponding wiring symbols listed in the following Table.

P.C.B. pattern diagram indication	Corresponding part symbol	Part Name
		Transistor
		Radiator type transistor
		Diode
		Resistor
		Capacitor (Polarized)
		Capacitor (Non-polarized)

Others

P.C.B. pattern diagram indication	Part Name
	IC
	Switch
	Relay
	Coil
	Filter
	Variable resistor or Semi-fixed resistor

3. The capacitor terminal marked with ⊕ (double circles) shows negative terminal.
4. The diode terminal marked with ⊕ (double circles) shows cathode side.
5. The transistor terminal to which E is affixed shows the emitter.

TUNER assembly (AWZ3938)

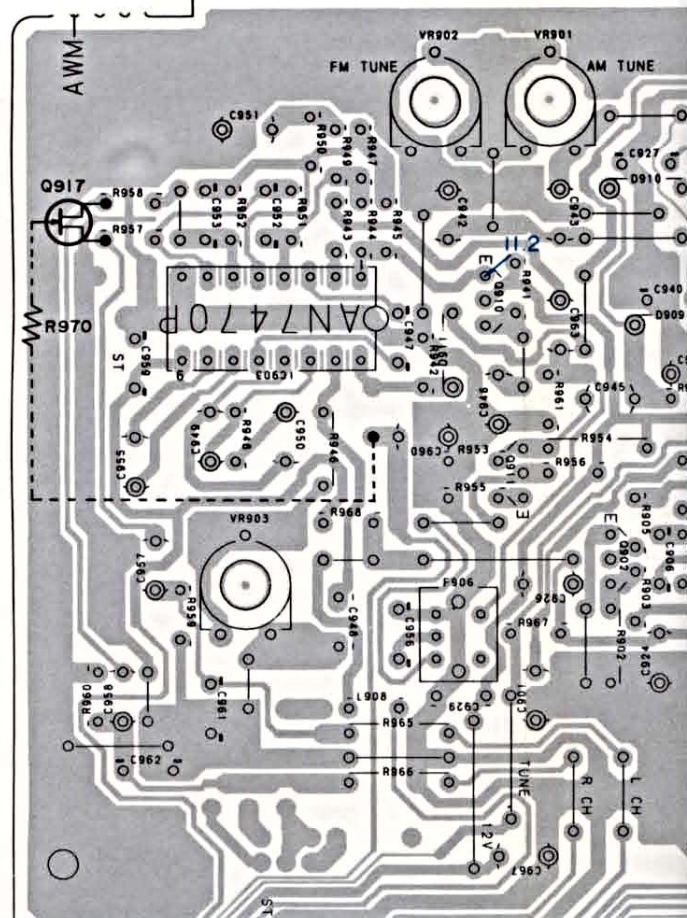

HEWZI ONLY

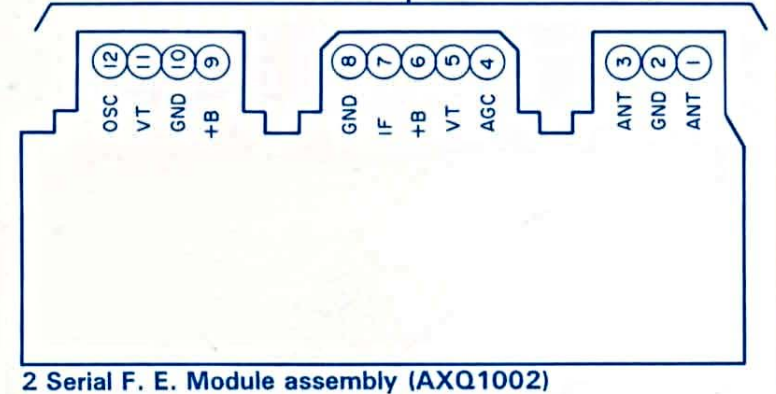
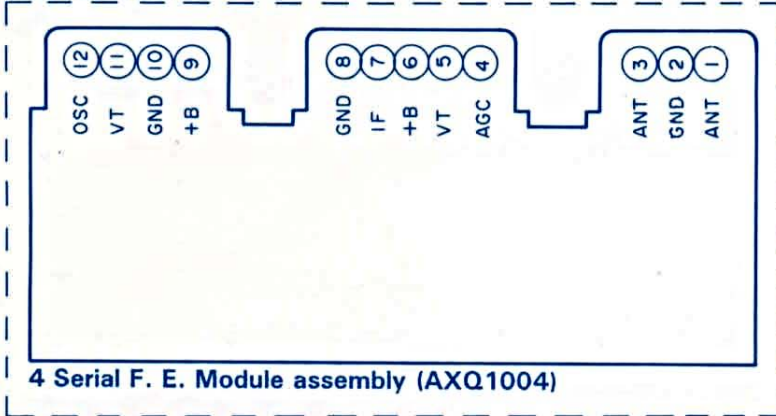

To POWER assembly CN4 (➔ P21)

To FRONT assembly J10 (➔ P32)

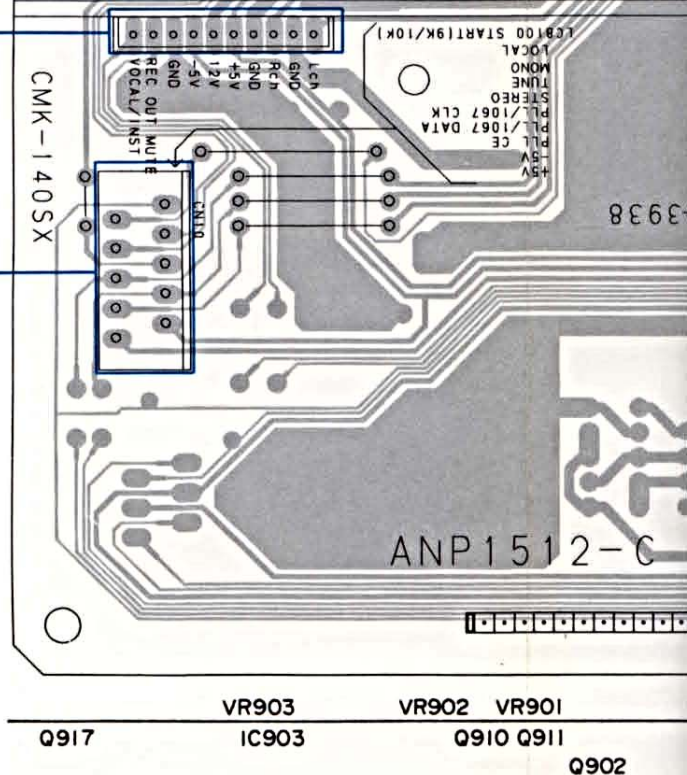
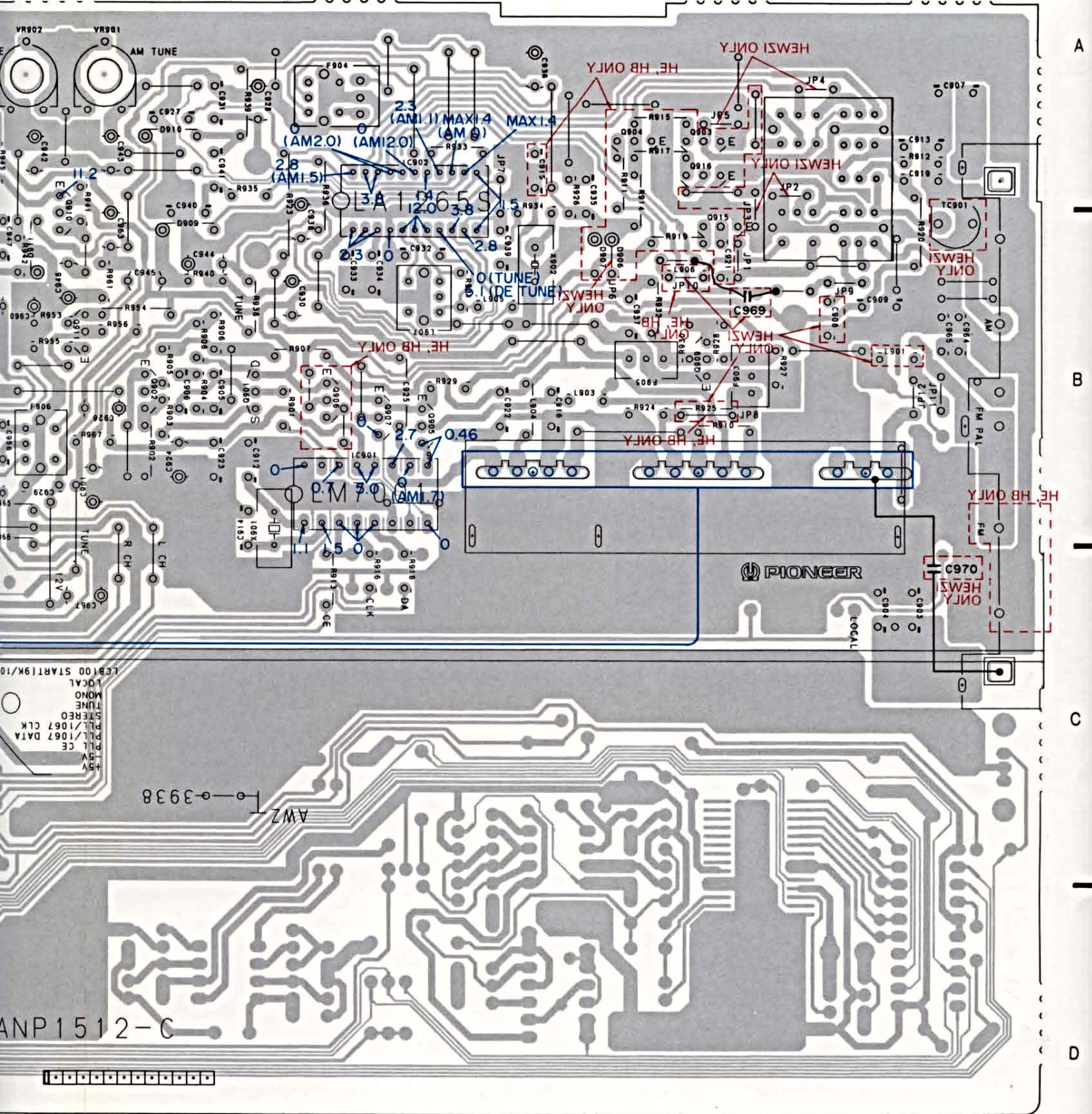

Diagram for HEWZI type, refer to page 49.

Assembly (AWZ3938)



VR902 VR901

Q910 Q911

Q902

Q901

Q906 IC902 IC901 Q907 Q905

Q904 Q903 Q916 Q915

Q909

ANP 1512-C

11

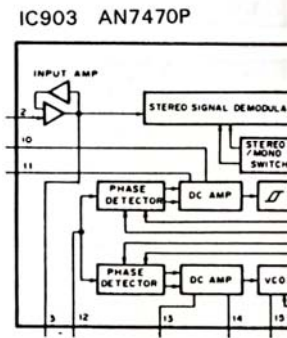
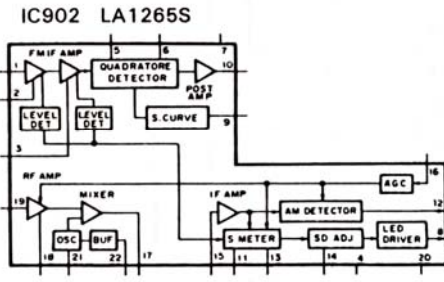
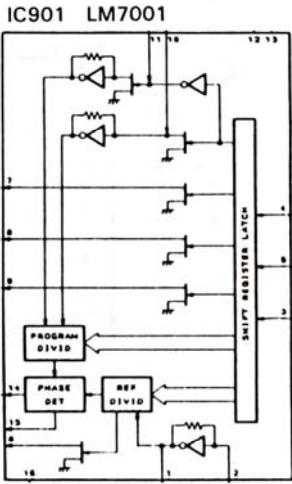

TUNER assembly (AWZ3938)

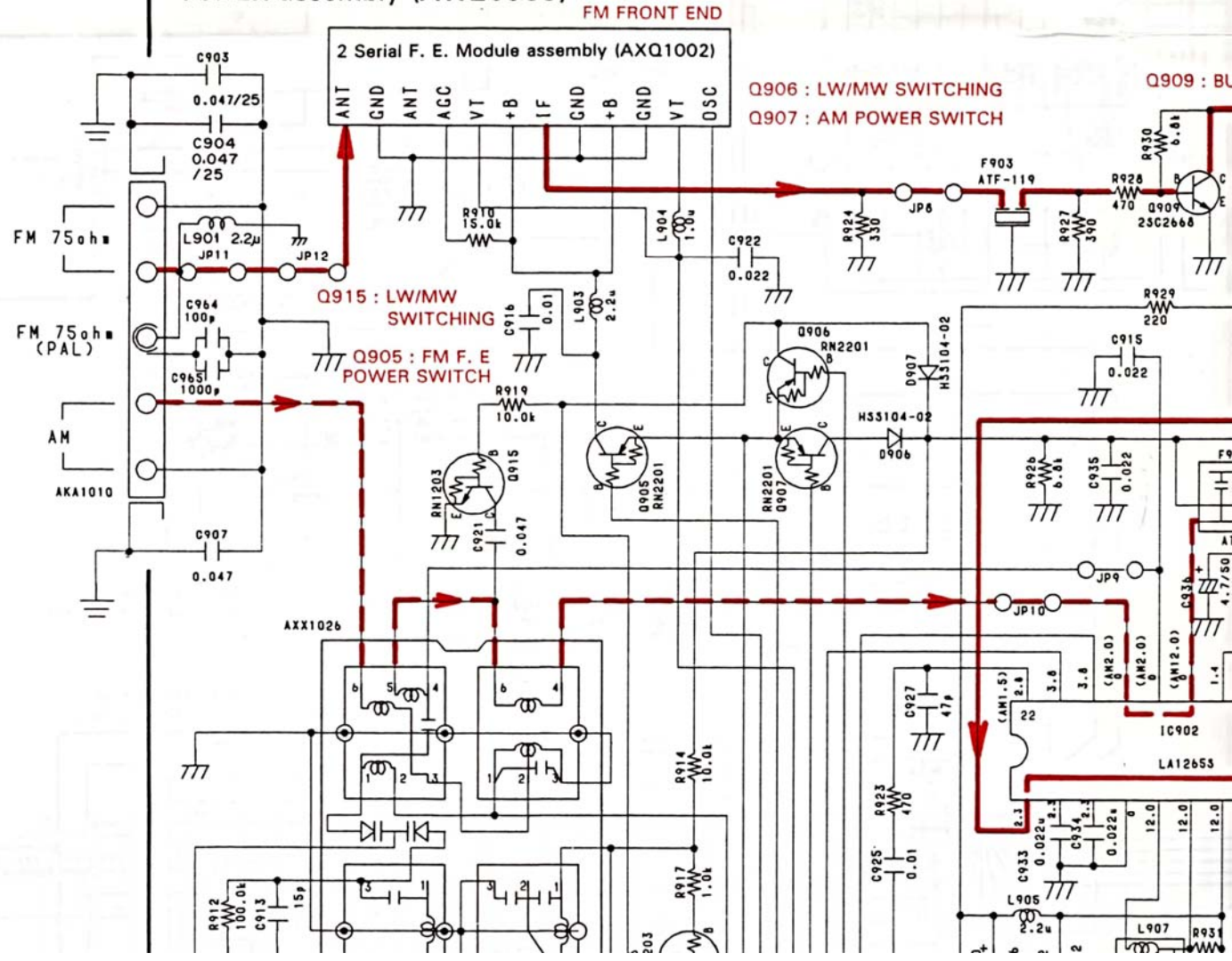

3 AN7470P

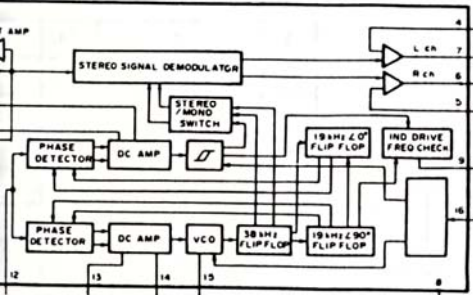

S-METER

VCO

TP904

TP905

Q909 : BUFFER

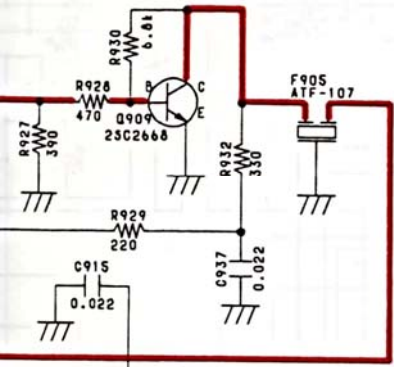

1

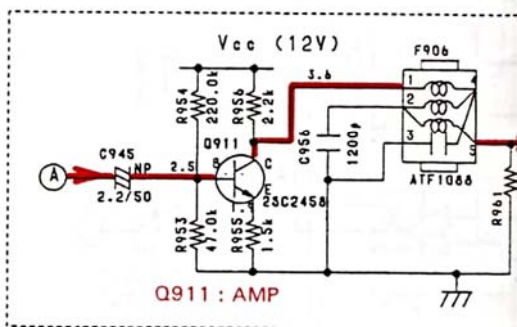

Q911 : AMP

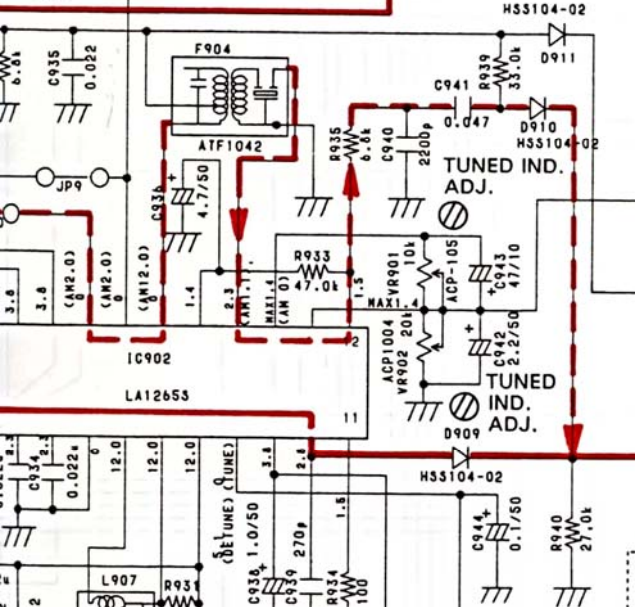

VCO ADJ.

ACPI015

IC903 : FM MPX

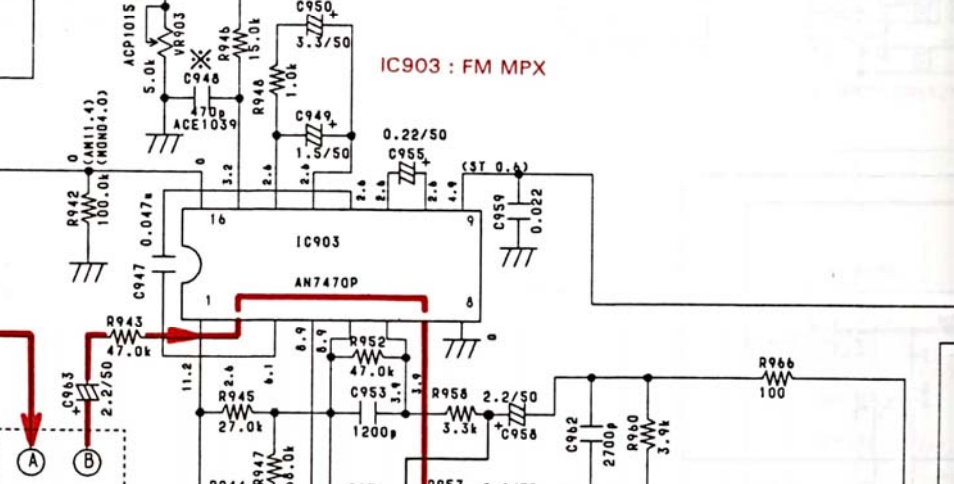

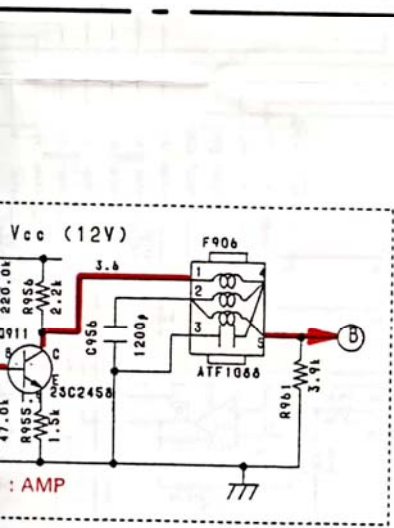

FM & AM SIGNAL
AM SIGNAL

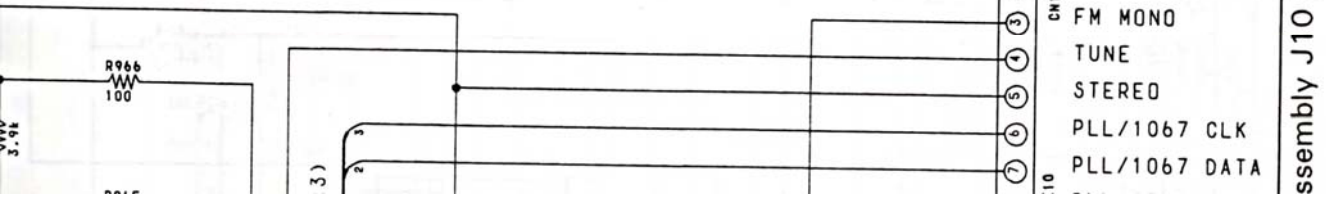

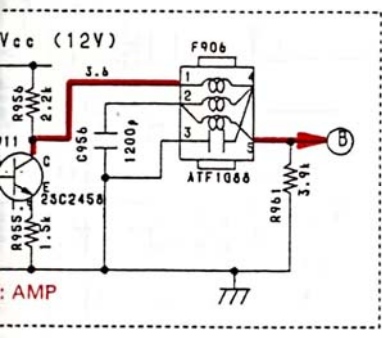

——— FM & AM SIGNAL
- - - - AM SIGNAL

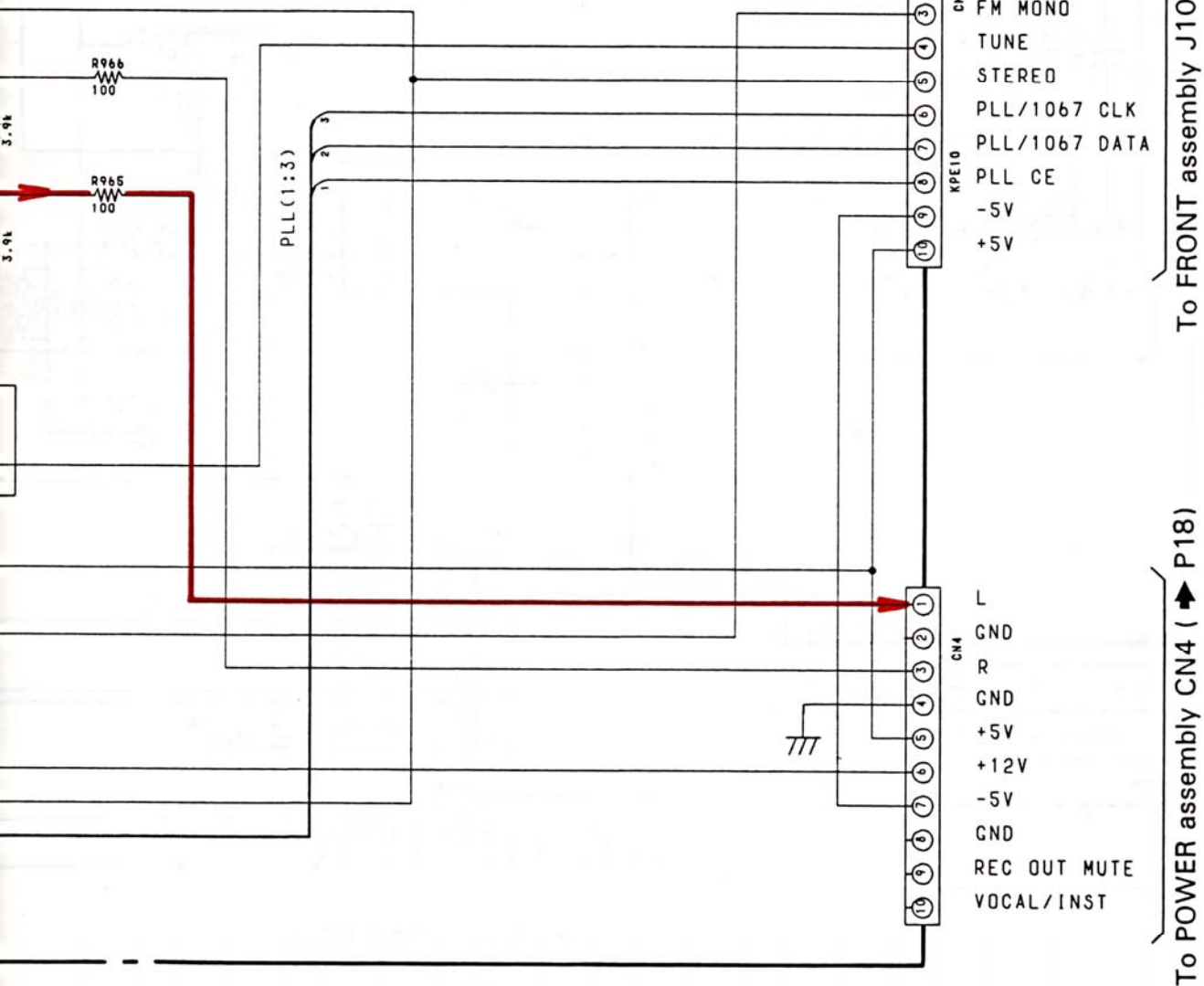

To FRONT assembly J10 (▲ P34)

To POWER assembly CN4 (▲ P18)

Q909 : BUFFER

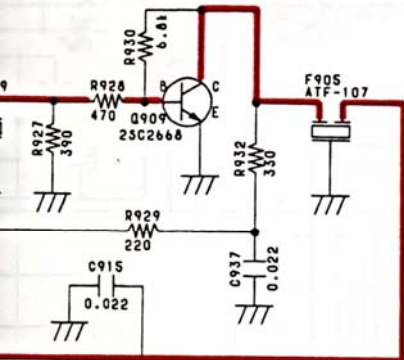

1

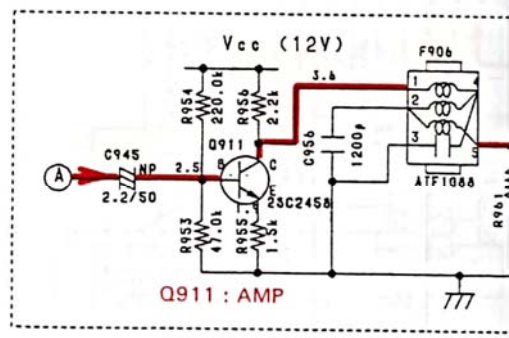

Q911 : AMP

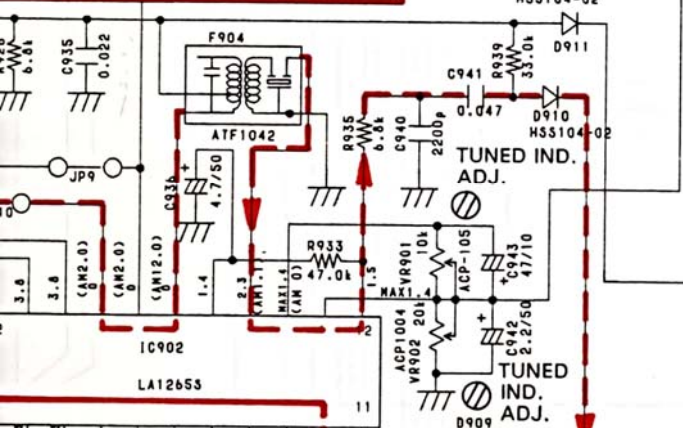

VCO ADJ.

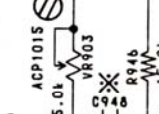

IC903 : FM MPX

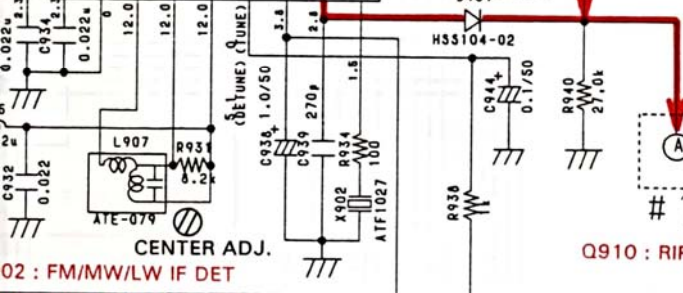
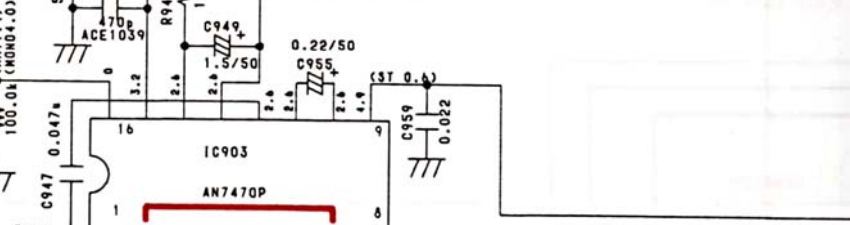

Q910 : RIPPLE FILTER

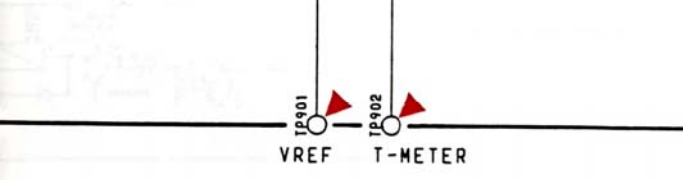
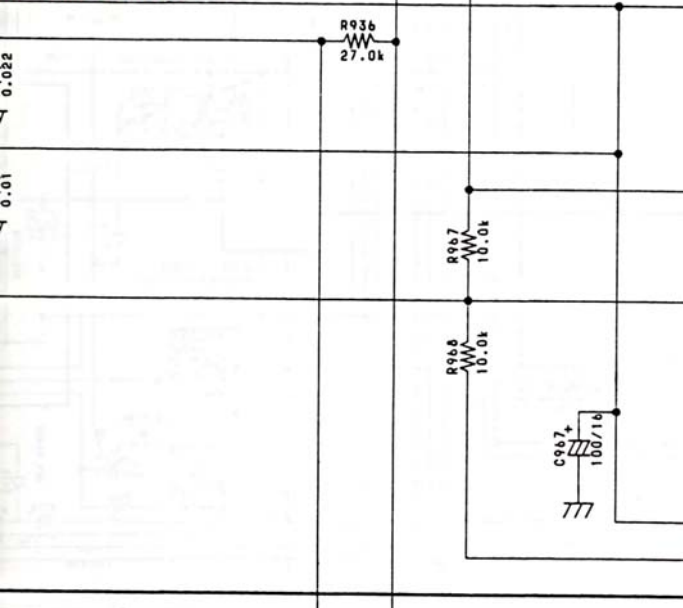

VREF T-METER

C
D
E
F

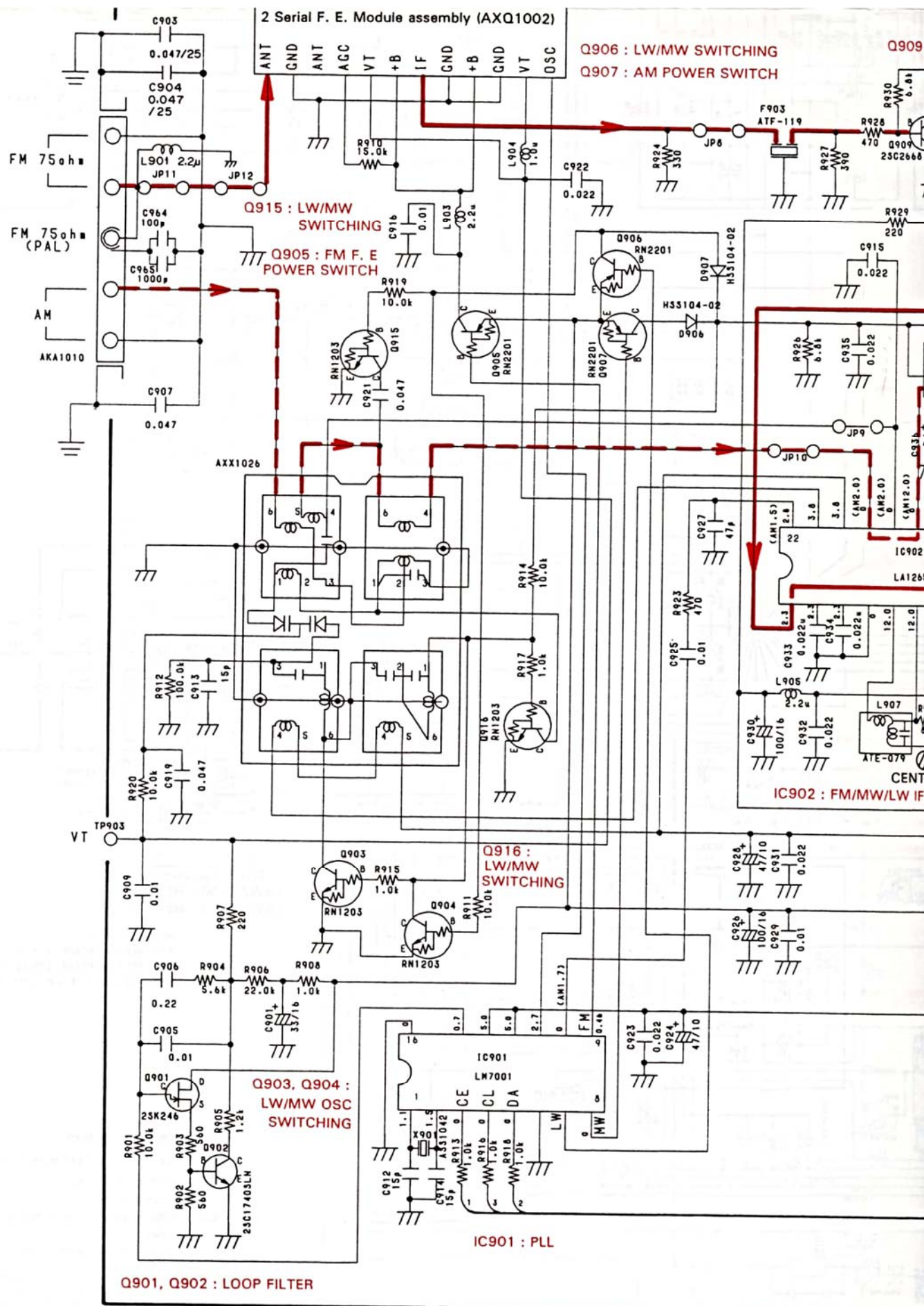

FRONT assembly CN3 (P 33)

- RESET
- VFDP
- POWER
- DISP. CLK
- DISP. DATA
- SP RY
- S. CLK
- S. DATA
- CD RED/EN
- TAPE RED/EN
- TRE1
- TRE2
- BASS1
- BASS2
- WIDE1
- WIDE2
- N.C
- N.C
- 4052INH
- 4052B
- 4052A

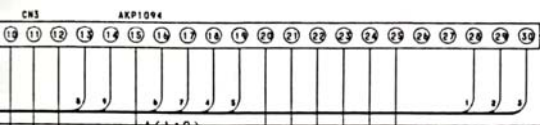

IC501 STK4152-2GP

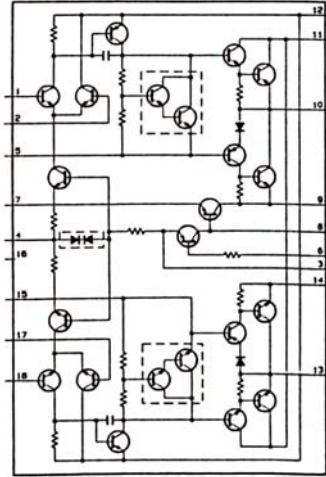

To VOLUME assembly J5 (P 33)

- L CND
- R -5V
- +5V
- M. +5V
- M. CND
- N.C
- N.C

IC401 (PA0049)

Pin No.	Voltage	Pin No.
1	4.7	11
2	0	12
3	0	13
4	0	14
5	0	15
6	0	16
7	0	17
8	0	18
9	0	19
10	0	20

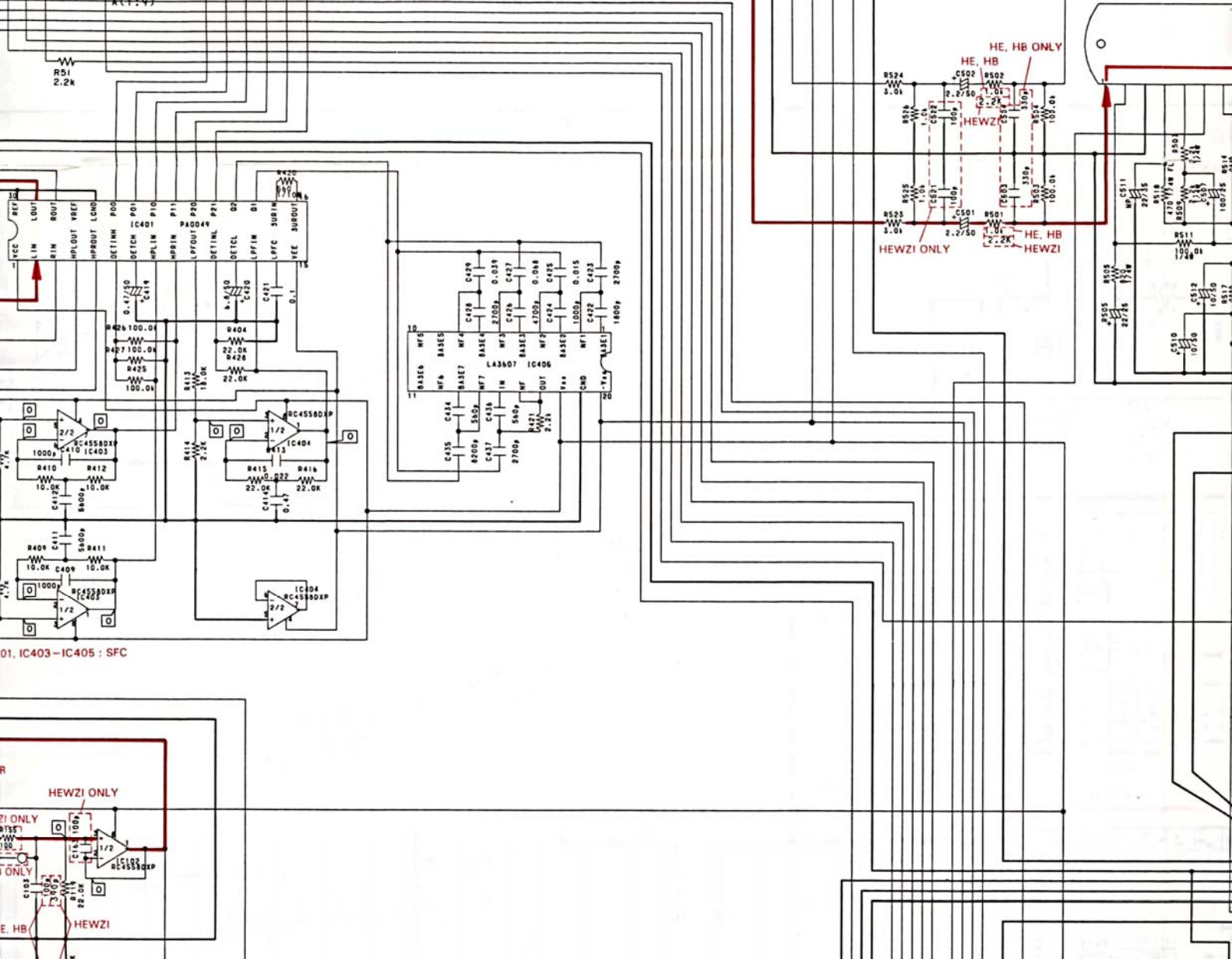

01, IC403-IC405 : SFC

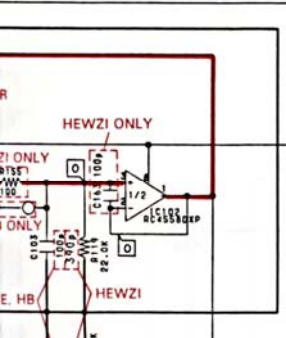

IC501 : POWER AMP

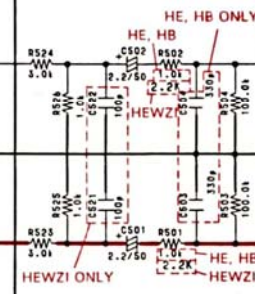

Voltage	Pin No.	Voltage	Pin No.	Voltage
4.7	11	0	21	0
0	12	0	22	0
0	13	0	23	0
0	14	0	24	0
0	15	-5.2	25	0
0	16		26	0
0	17		27	0
0	18		28	0
0	19		29	0
0	20		30	0

IC405 (LA3607)

Pin No.	Voltage	Pin No.	Voltage
1	-0.1	11	-0.1
2	-0.8	12	-0.8
3	-0.1	13	-0.1
4	-0.8	14	-0.8
5	-0.1	15	-0.1
6	-0.8	16	-0.8
7	-0.1	17	-0.8
8	-0.8	18	4.7
9	-0.1	19	0
10	-0.8	20	-5.2

IC501 (STK4152-2GP)

Pin No.	Voltage	Pin No.	Voltage
1	-0.3	10	0
2	-0.3	11	32.4
3	0	12	30.8
4	-26.8	13	0
5	-1.3	14	-32.4
6	4.8 -1.7 (When STANDBY)	15	-1.3
7	-31.6	16	0
8	-32.3	17	-0.3
9	-32.5	18	-0.3

DIODES

D702,703,704,705,708,709,718,719:5556b

Other Diodes:1SS252 except zenor diode

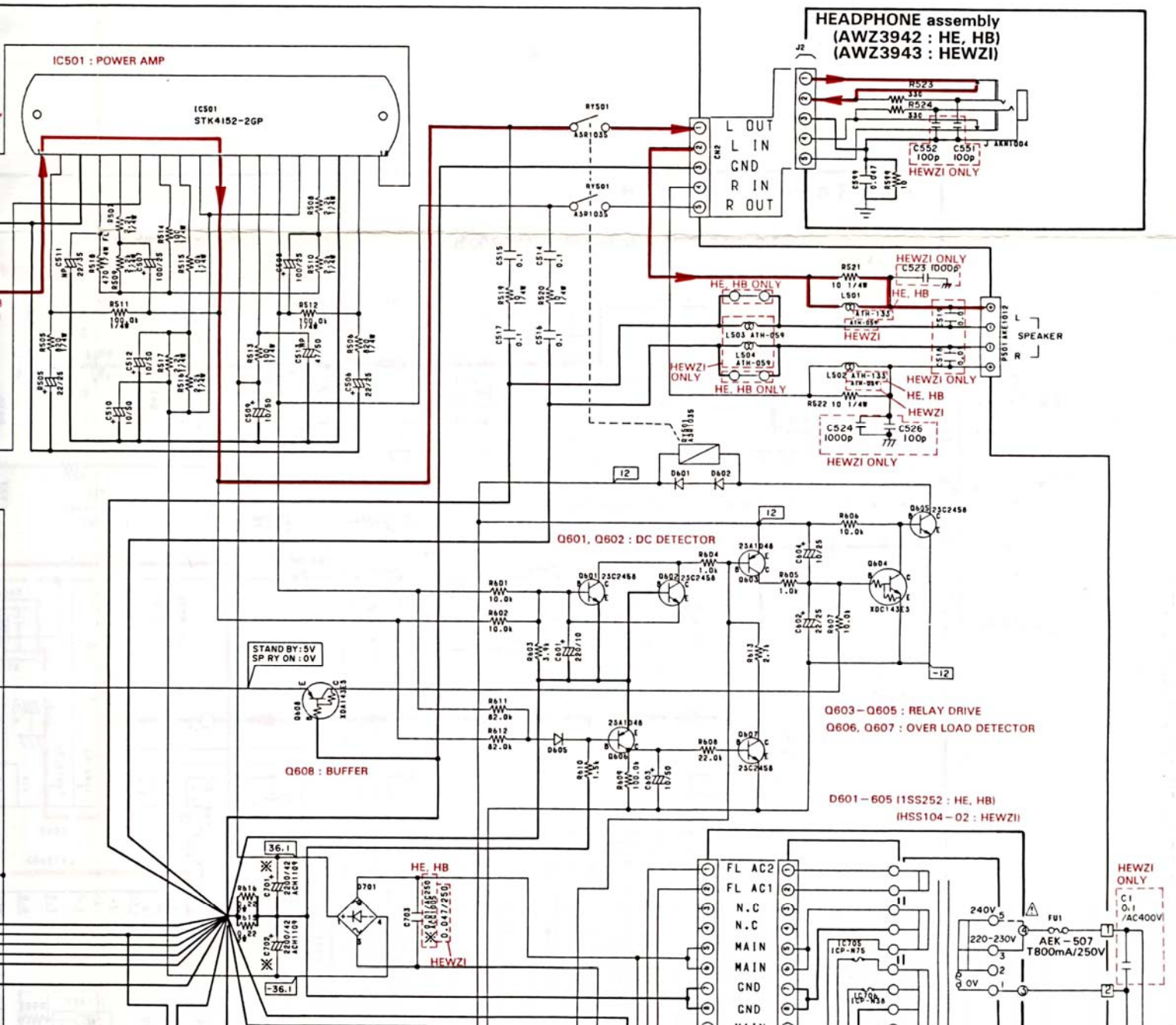

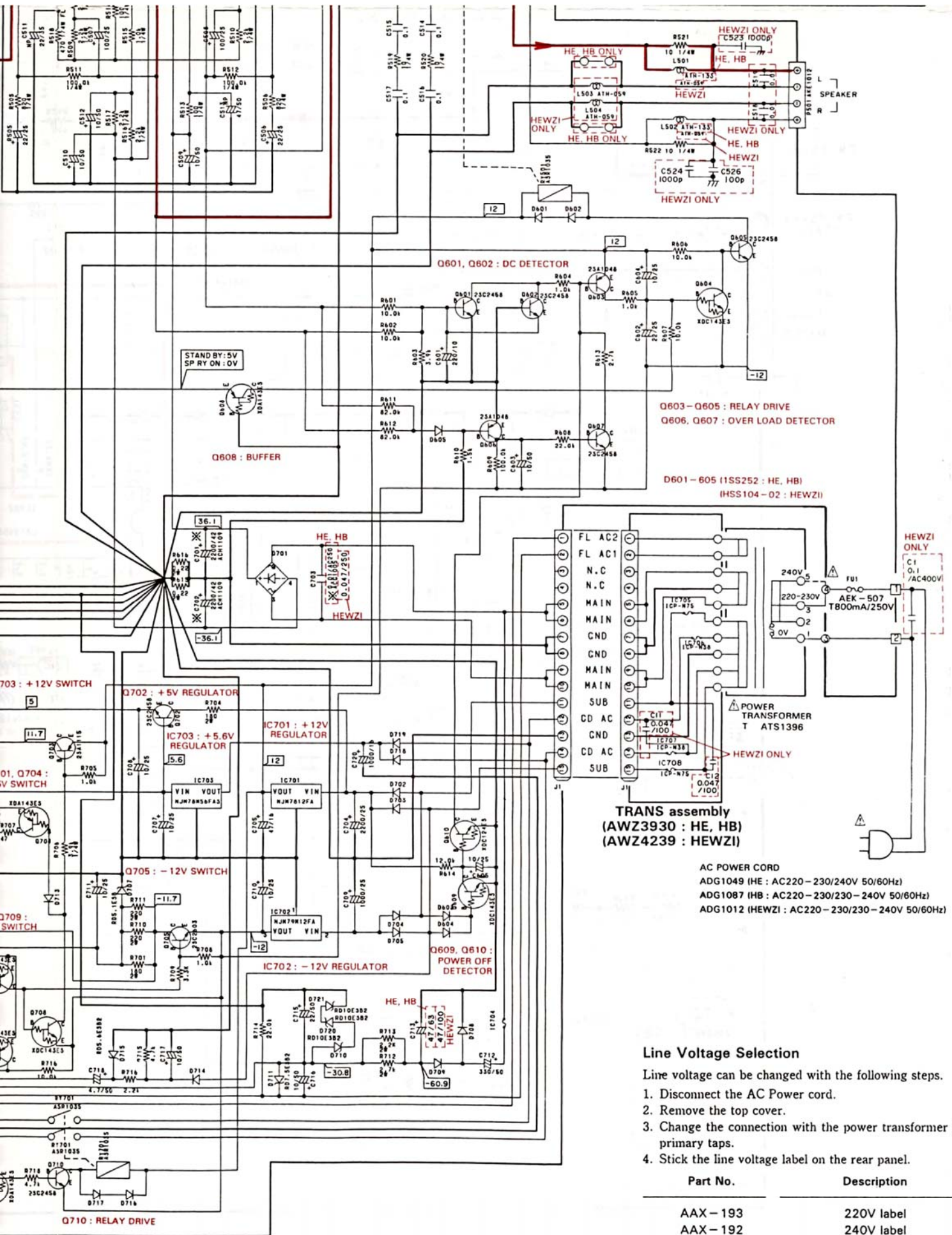

Line Voltage Selection

Line voltage can be changed with the following steps.

1. Disconnect the AC Power cord.
2. Remove the top cover.
3. Change the connection with the power transformer (T) primary taps.
4. Stick the line voltage label on the rear panel.

Part No.	Description
AAX-193	220V label
AAX-192	240V label

To TUNER assembly CN4 (▲ P17 : HE, HB)
 (▲ P50 : HEWZI)

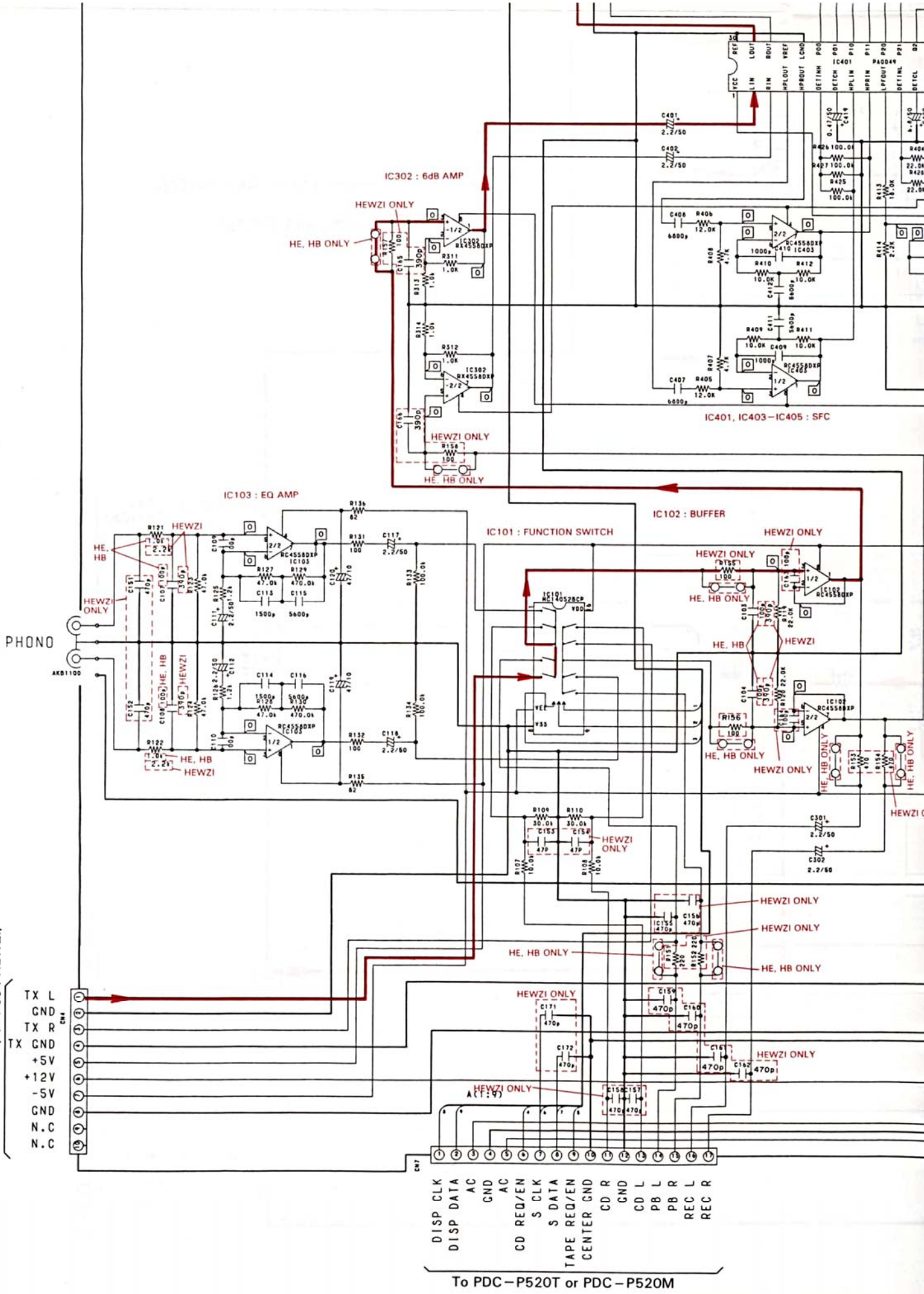

To PDC-P520T or PDC-P520M

1

2

3

A

B

C

D

IC701
IC702
Q707
Q708
IC501

Q702
Q705

Q709

Q701

Q601

Q610

IC405

Q711

Q710

IC401

IC403
IC404

IC704

IC302

IC103

IC102
IC101

1

2

3

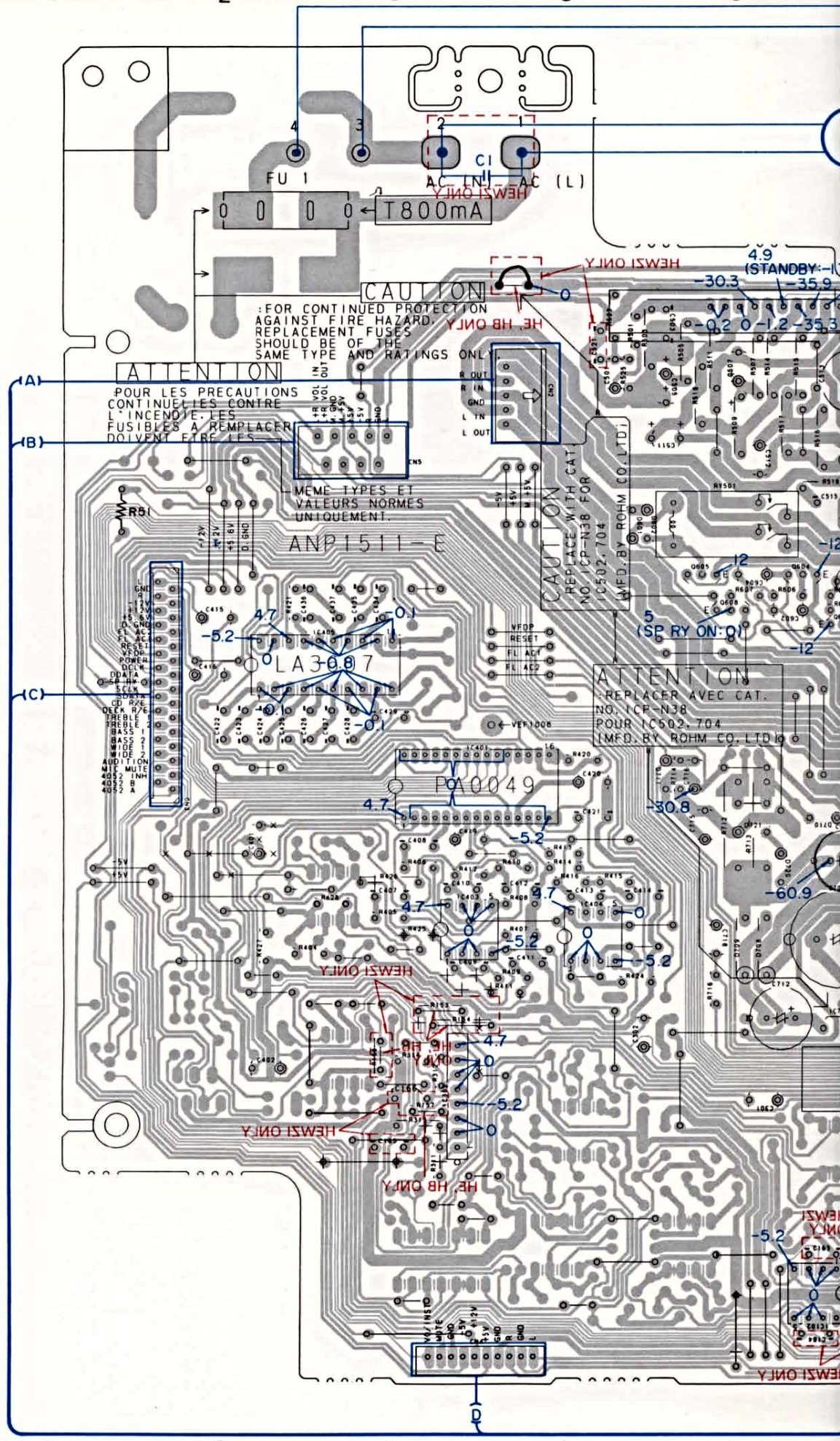

1

2

3

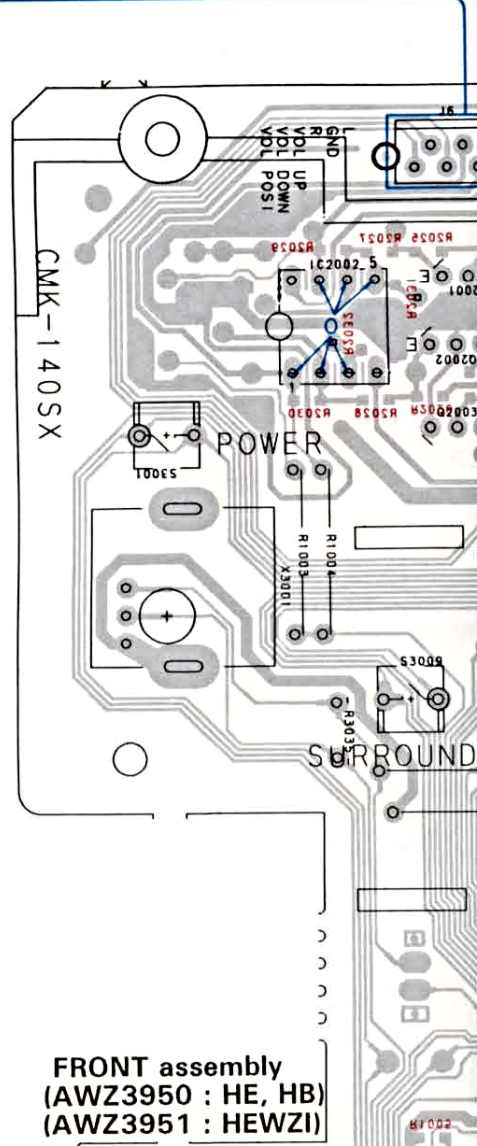
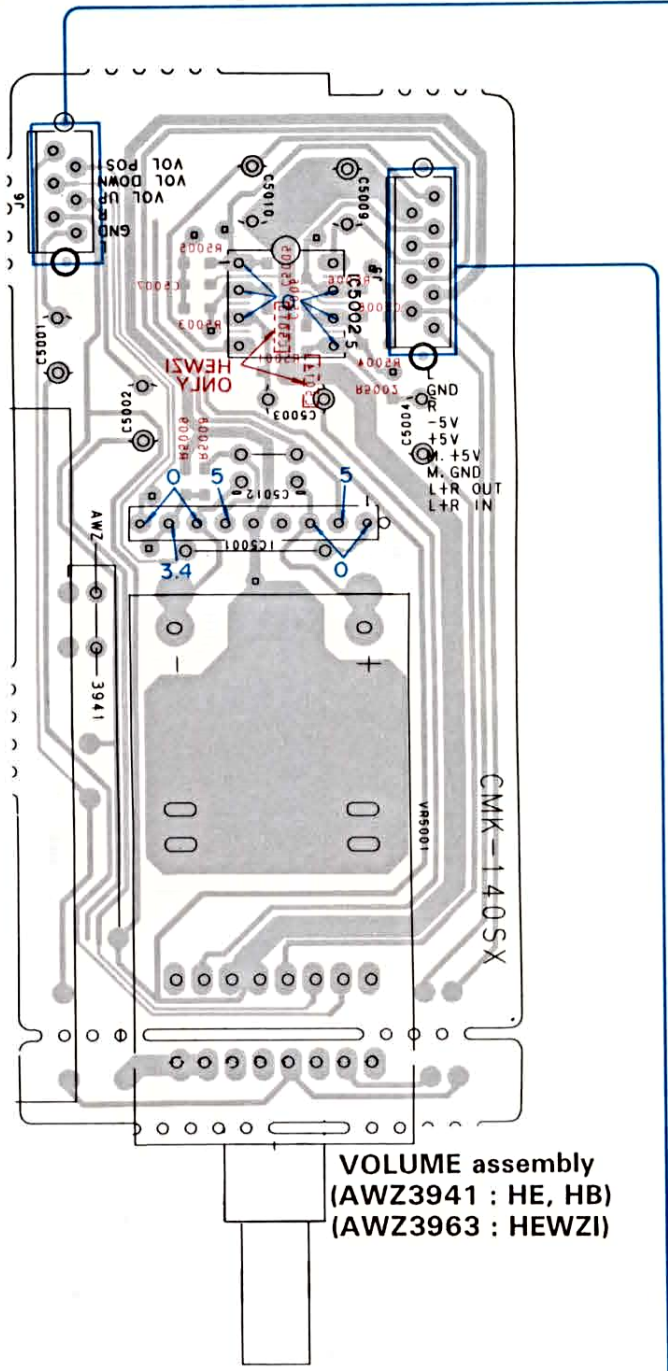

FRONT assembly
(AWZ3950 : HE, HB)
(AWZ3951 : HEWZI)

To POWER assembly CN5 (➔ P21)

NOTE

1. This P.C.B. connection diagram is viewed from the parts mounted side.
2. The parts which have been mounted on the board can be replaced with those shown with the corresponding wiring symbols listed in the following Table.

P.C.B. pattern diagram indication	Corresponding part symbol	Part Name
		Transistor
		Radiator type transistor
		Diode
		Resistor
		Capacitor (Polarized)
		Capacitor (Non-polarized)

Others

P.C.B. pattern diagram indication	Part Name
	IC
	Switch
	Relay
	Coil
	Filter
	Variable resistor or Semi-fixed resistor

3. The capacitor terminal marked with ⊕ (double circles) shows negative terminal.
4. The diode terminal marked with ⊕ (double circles) shows cathode side.
5. The transistor terminal to which E is affixed shows the emitter.

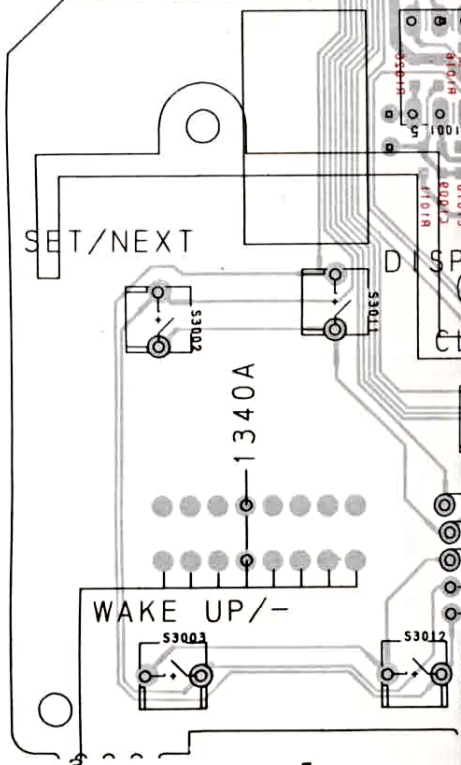

This P. C. B connection diagram is viewed from the parts mounted side.

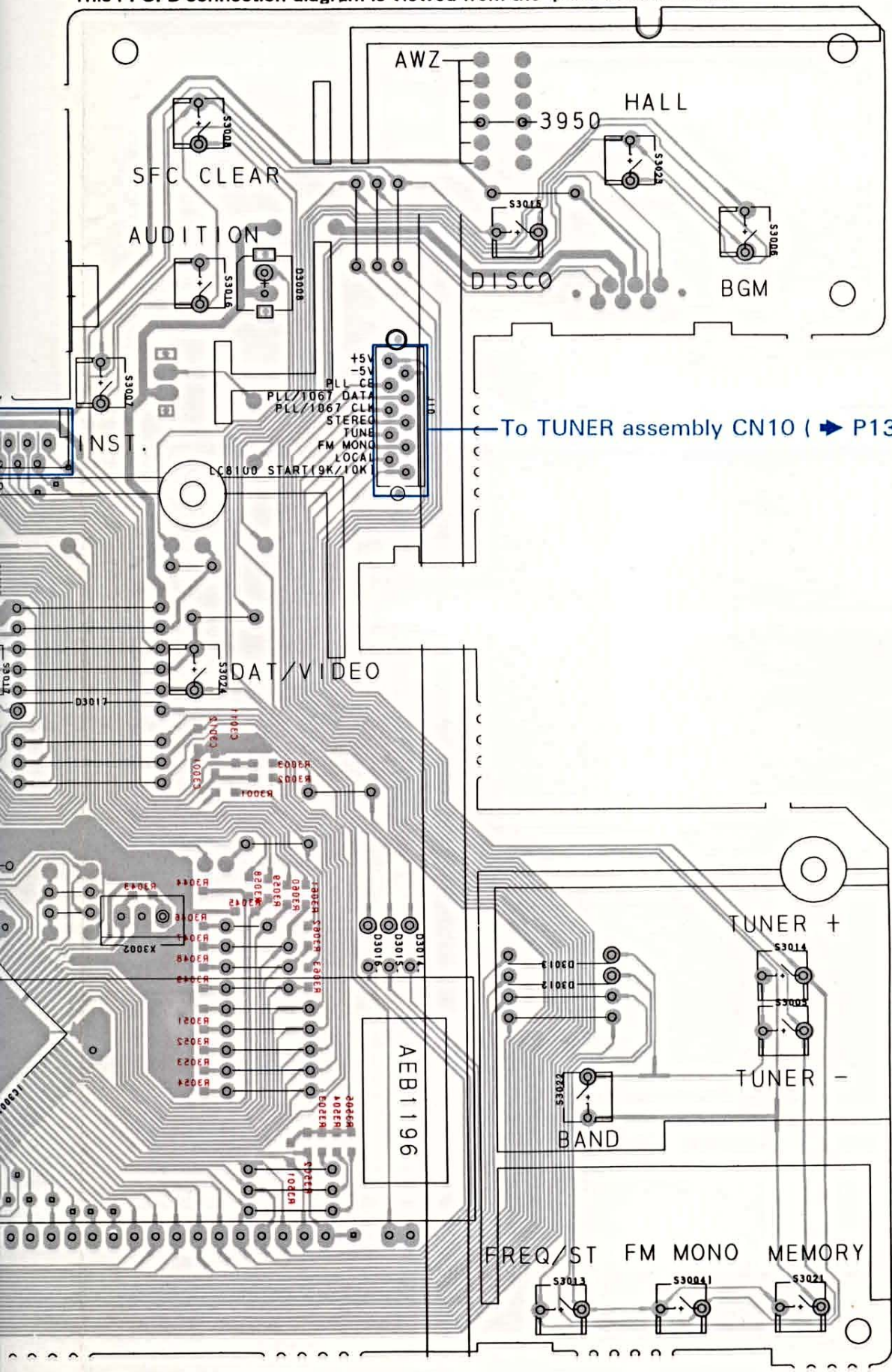

- IC2001
- IC2002
- Q2001
- Q2002
- Q2003
- VR2001
- Q3001
- Q3002
- IC3001

A
B
C
D

7

8

9

7

8

9

A

B

C

D

**FRONT assembly (AWZ3950 : HE, HB)
(AWZ3951 : HEWZI)**

P.BASS

TREBLE

+16dB AMP

To POWER assembly CN3 (P18)

- L
- GND
- R
- 12V
- +12V
- +5.6V
- D.GND
- FL AC2
- FL AC1
- RESET
- Vfd₁
- POWER
- DISP CLK
- DISP DATA
- SP RV
- S.CLK
- S.DATA
- CD REQ/EN
- DECK REQ/EN
- TREBLE 1
- TREBLE 2
- BASS 1
- BASS 2
- WIDE 1
- WIDE 2
- AUDITION
- MIC MUTE
- 4052 INH
- 4052 B
- 4052 A

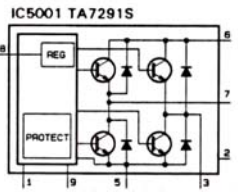
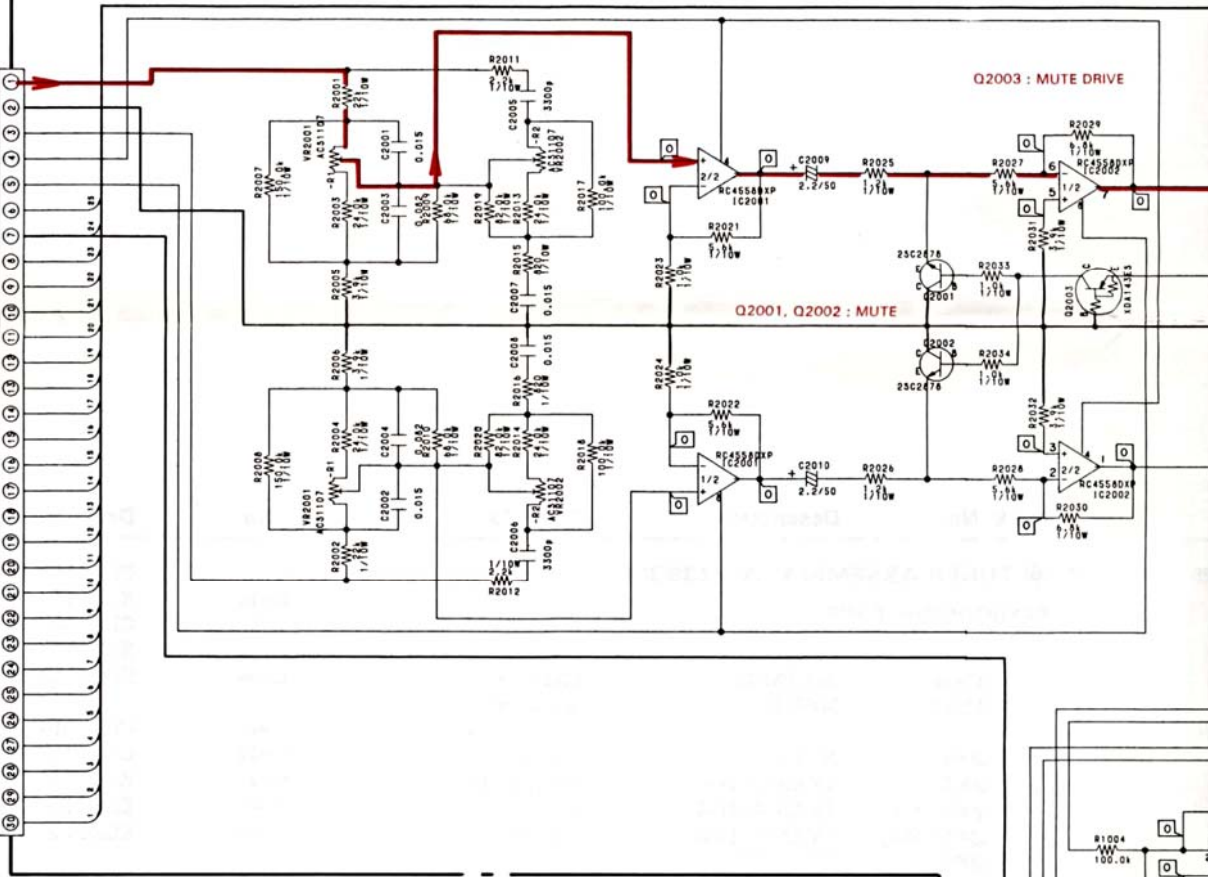

**VOLUME assembly (AWZ3941 : HE, HB)
(AWZ3963 : HEWZI)**

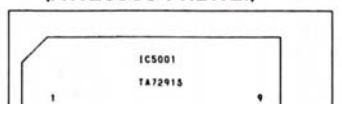

To TUNER assembly CN10 (→ P17 : HE, HB)
 (→ P50 : HEWZI)

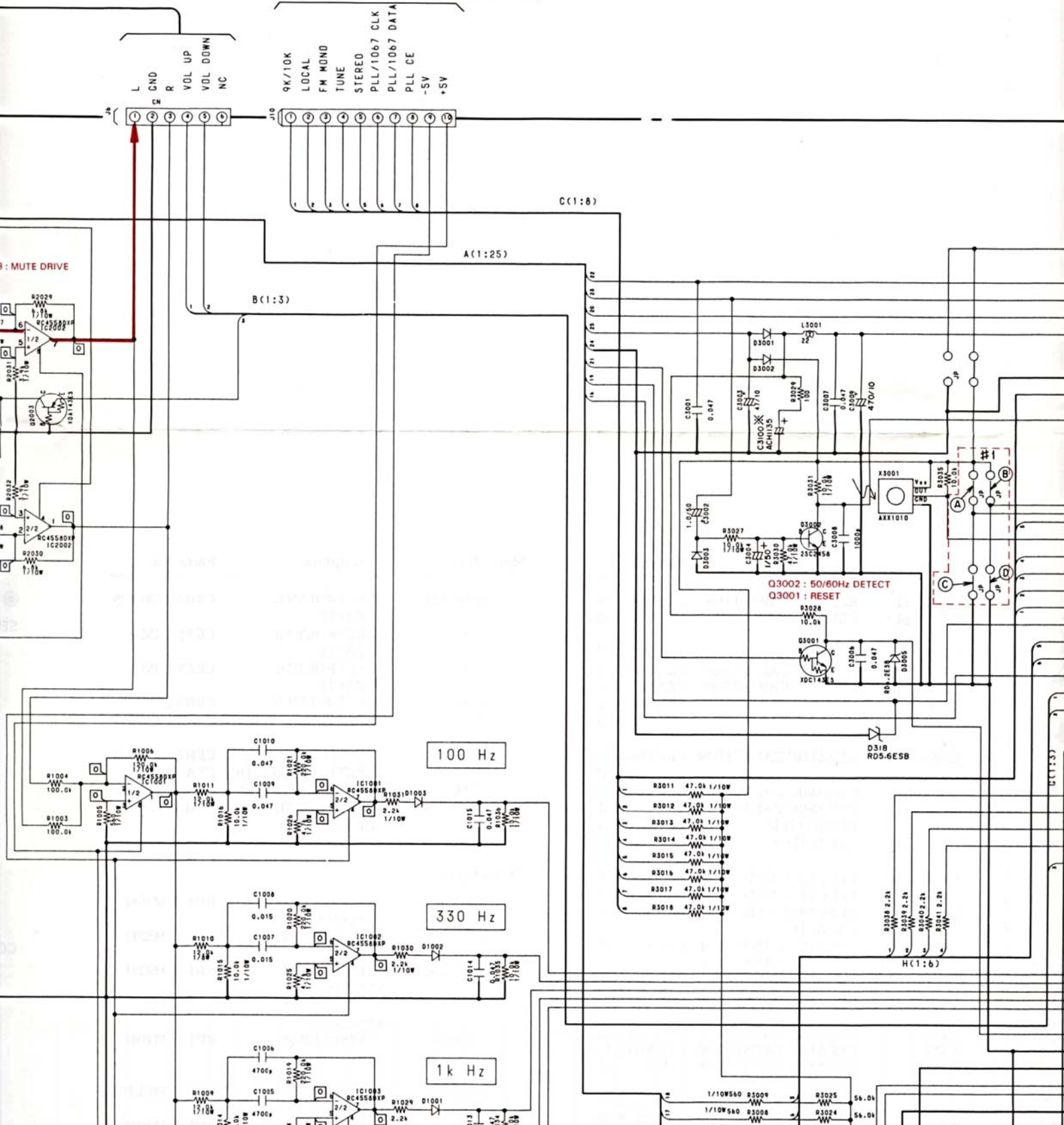

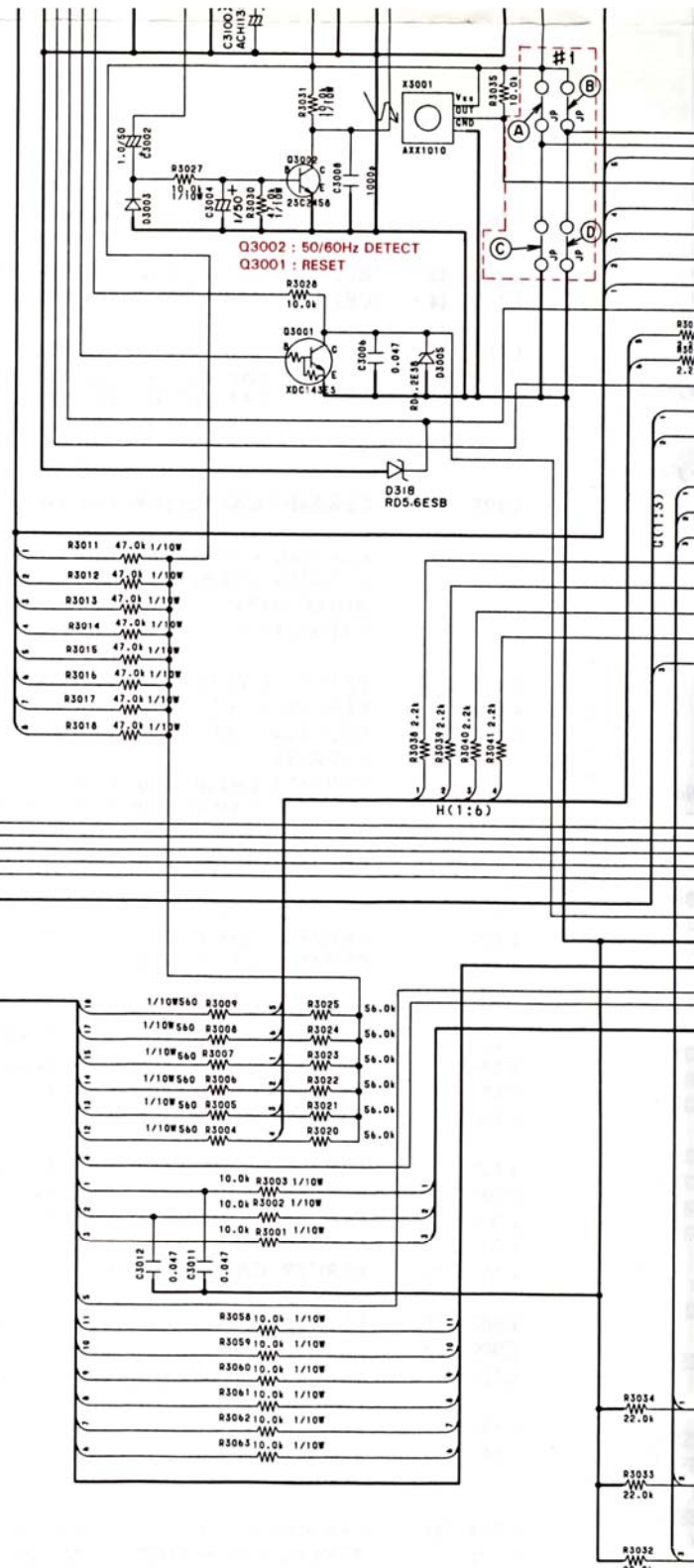
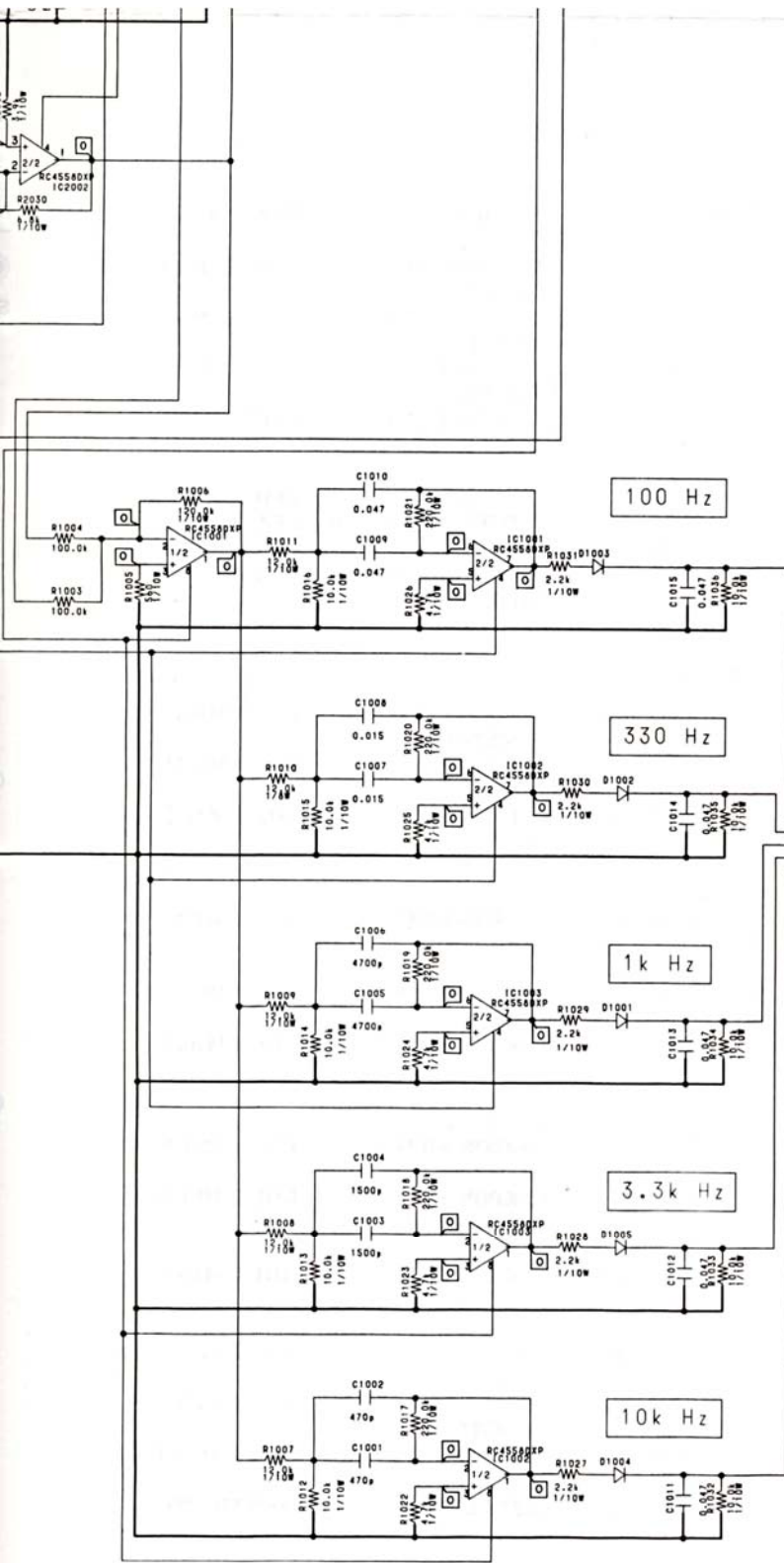

D1001-1005, 3001-3003, 3009-3017 (15S252 :HE, HB)
(HSS104-02 : HEWZI)

- To POWER assembly CN3 (▲)
- Vfd
 - POWER
 - DISP CLK
 - DISP DATA
 - SP RY
 - S.CLK
 - S.DATA
 - CD REQ/EN
 - DECK REQ/EN
 - TREBLE 1
 - TREBLE 2
 - BASS 1
 - BASS 2
 - WIDE 1
 - WIDE 2
 - AUDITION
 - MIC MUTE
 - 4052 INH
 - 4052 B
 - 4052 A

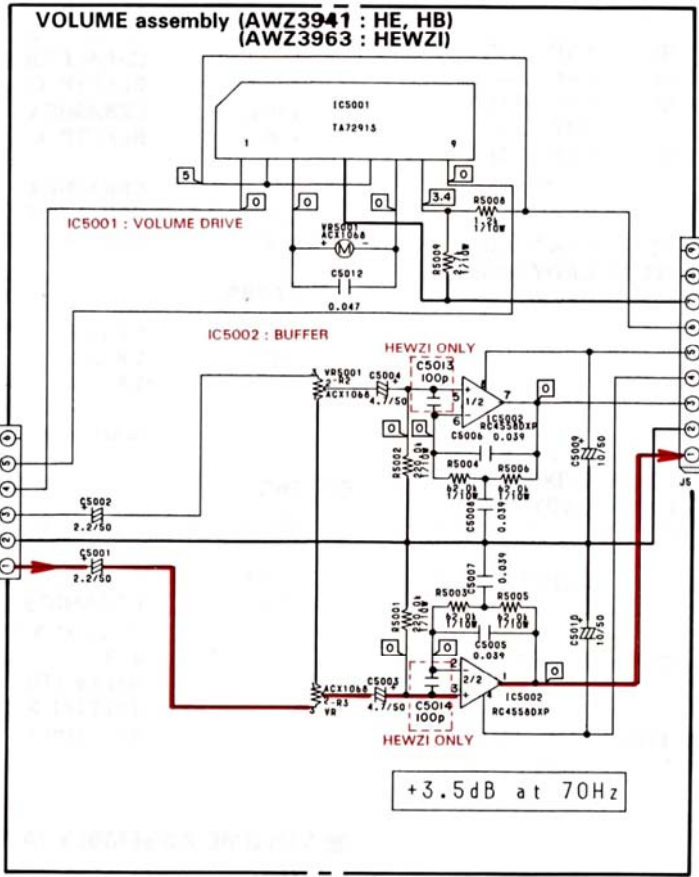
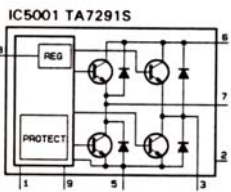
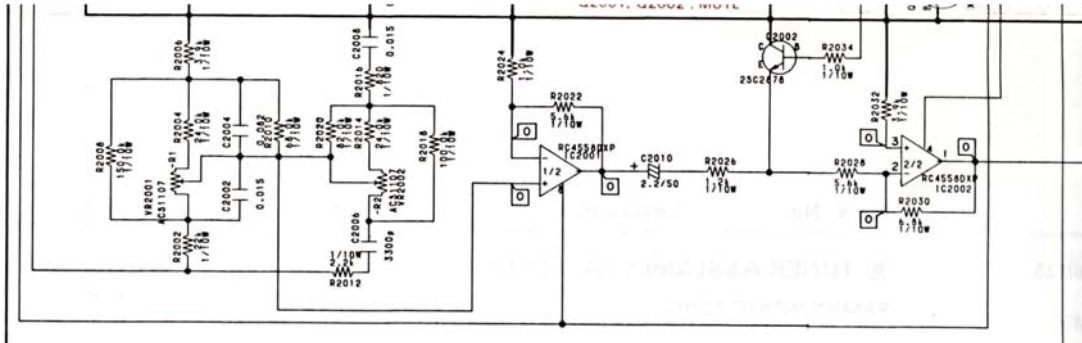

To POWER assembly CN5 (▲ P19)

- NC
- VOL DOWN
- VOL UP
- R
- GND
- L

- NC
- NC
- M.CND
- M.+5V
- +5V
- 5V
- R
- GND
- L

TL

Mark No.	Description	Parts No.
C111, 112	ELECTR. CAPACITOR	CEAS2R2M50
C113, 114	CERAMIC CAPACITOR	CKCYB152K50
C115, 116	CERAMIC CAPACITOR	CKCYB562K50
C117, 118	ELECTR. CAPACITOR	CEAS2R2M50
C119, 120	ELECTR. CAPACITOR	CEAS470M10
C301, 302	ELECTR. CAPACITOR	CEAS2R2M50
C401, 402	ELECTR. CAPACITOR	CEAS2R2M50
C407, 408	CERAMIC CAPACITOR	CKCYB682K50
C409, 410	CERAMIC CAPACITOR	CKCYB102K50
C411, 412	CERAMIC CAPACITOR	CKCYB562K50
C413	CERAMIC CAPACITOR	CKCYX223M25
C414	AUDIO FILM CAPACITOR	CFTXA474J50
C415, 416	ELECTR. CAPACITOR	CEAS2R2M50
C419	ELECTR. CAPACITOR	CEASR47M50
C420	ELECTROLYTIC CAPACIT	CEAS6R8M50
C421	CERAMIC CAPACITOR	CKCYX104M25
C422	CERAMIC CAPACITOR	CKCYB182K50
C423	CERAMIC CAPACITOR	CKCYX273M25
C424	CERAMIC CAPACITOR	CKCYB102K50
C425	CERAMIC CAPACITOR	CKCYX153M25
C426	CERAMIC CAPACITOR	CKCYB472K50
C427	CERAMIC CAPACITOR	CKCYX683M25
C428	CERAMIC CAPACITOR	CKCYB272K50
C429	CERAMIC CAPACITOR	CKCYX393M25
C434	CERAMIC CAPACITOR	CKCYB561K50
C435	CERAMIC CAPACITOR	CKCYB822K50
C436	CERAMIC CAPACITOR	CKCYB561K50
C437	CERAMIC CAPACITOR	CKCYB272K50
C501	ELECTR. CAPACITOR	CEAS2R2M50
C502	ELECTR. CAPACITOR	CEAS2R2M50
C503, 504	CERAMIC CAPACITOR	CKCYB331K50
C505, 506	ELECTR. CAPACITOR	CEAS220M25
C507, 508	ELECTR. CAPACITOR	CEAS101M25
C509, 510	ELECTR. CAPACITOR	CEAS100M50
C511	ELECTROLYTIC CAPACIT	CEANP220M35
C512	ELECTR. CAPACITOR	CEAS100M50
C513	ELECTROLYTIC CAPACIT	CEANP470M50
C514-517	CERAMIC CAPACITOR	CKCYX104M25
C601	ELECTR. CAPACITOR	CEAS221M10
C602	ELECTR. CAPACITOR	CEAS220M25
C603, 604	ELECTR. CAPACITOR	CEAS100M50
C605	ELECTR. CAPACITOR	CEAS100M25
C701, 702	ELECTROLYTIC CAPACIT (2200/42)	ACH1109
C703	CKA (0.01/AC250V)	ACG1005
C704	ELECTR. CAPACITOR	CEAS222M25
C705	ELECTROLYTIC CAPACIT	CEHAQ470M16
C707, 708	ELECTR. CAPACITOR	CEAS100M25
C709	ELECTR. CAPACITOR	CEAS102M25

Mark No.	Description	Parts No.
C710, 711	ELECTROLYTIC CAPACIT	CEHAQ100M25
C712	ELECTROLYTIC CAPACIT	CEAS331M50
C713	ELECTROLYTIC CAPACIT	CEAS470M63
C715	ELECTROLYTIC CAPACIT	CEHAQ220M50
C716	ELECTR. CAPACITOR	CEHAQ100M50
C717	ELECTR. CAPACITOR	CEAS100M50
C718	ELECTR. CAPACITOR	CEAS4R7M50
C719	ELECTROLYTIC CAPACIT	CEHAQ470M50
C720	ELECTR. CAPACITOR	CEAS102M16
RESISTORS		
R503, 504	CARBON FILM RESISTOR	RD1/4PM104J
R505, 506	CARBON FILM RESISTOR	RD1/4PM821J
R507-509	CARBON FILM RESISTOR	RD1/4PM222J
R510	CARBON FILM RESISTOR	RD1/4PM222J
R511, 512	CARBON FILM RESISTOR	RD1/4PM104J
R513, 514	CARBON FILM RESISTOR	RD1/4PMFL101J
R515	CARBON FILM RESISTOR	RD1/4PM102J
R516	CARBON FILM RESISTOR	RD1/4PM222J
R517	CARBON FILM RESISTOR	RD1/4PMFL222J
R518	CARBON FILM RESISTOR	RD1/4PMFL471J
R519, 520	CARBON FILM RESISTOR	RD1/4PM100J
R521, 522	FUSIBLE RESISTOR	RFA1/4PL100J
R615, 616	METAL OXIDE RESISTOR	RS2LMFR22J
R701, 704	METAL OXIDE RESISTOR	RS2LMF181J
R706	CARBON FILM RESISTOR	RD1/4PM392J
R710, 711	METAL OXIDE RESISTOR	RS2LMF221J
R712	METAL OXIDE RESISTOR	RS2LMF222J
R713	METAL OXIDE RESISTOR	RS2LMF272J
	Other resistors	RD1/8PM□□□J
OTHERS		
CN3	30P SOCKET	AKP1094
CN5	CONNECTOR (9P)	KPE9
CN7	SOCKET (17P)	AKP1101
	PIN JACK 2P (PHONO)	AKB1100
	SPEAKER TERMINAL 4-P	AKE1012

Mark No.	Description	Parts No.
◎ TUNER ASSEMBLY (AWZ3938)		
SEMICONDUCTORS		
IC901	PLL IC	LM7001
IC902	AM/FM IC	LA1265S
IC903	MPX IC	AN7470P
Q901	N-FET	2SK246
Q902	TRANSISTOR	2SC1740SLN
Q903, 904	TRANSISTOR	RN1203
Q905-907	TRANSISTOR	RN2201
Q909	TRANSISTOR	2SC2668
Q910, 911	TRANSISTOR	2SC2458
Q915, 916	TRANSISTOR	RN1203
Q917	N-FET	2SK246
D318	ZENER DIODE	RD5.6ESB
D906, 907	DIODE	HSS104-02
D909-911	DIODE	HSS104-02
COILS		
F903	CERAMIC FILTER	ATF-119
F904	CERAMIC FILTER	ATF1042
F905	CERAMIC FILTER	ATF-107
F906	FILTER	ATF1088
L901, 903	AXIAL INDUCTOR	LAU2R2M
L904	AXIAL INDUCTOR	LAU010M
L905	AXIAL INDUCTOR	LAU2R2M
L907	COIL	ATE-079
L908	AXIAL INDUCTOR	LAU2R2M
CAPACITORS		
C901	ELECTR. CAPACITOR	CEAS330M16
C903, 904	CERAMIC CAPACITOR	CKDYX473M25
C905	AUDIO FILM CAPACITOR	CFTXA103J50
C906	AUDIO FILM CAPACITOR	CFTXA224J50
C907	CERAMIC CAPACITOR	CKDYX473M25
C909	CERAMIC CAPACITOR	CKDYF103Z50
C912-914	CERAMIC CAPACITOR	CCDCH150J50
C915	CERAMIC CAPACITOR	CKDYF223Z50
C916	AXIAL CERAMIC CAPACITOR	CKPUYF103Z25
C919, 921	AXIAL CERAMIC CAPACITOR	CKPUYF473Z16
C922	CERAMIC CAPACITOR	CKDYF223Z50
C923	AXIAL CERAMIC CAPACITOR	CKPUYF223Z25
C924	ELECTR. CAPACITOR	CEAS470M10
C925	AXIAL CERAMIC CAPACITOR	CKPUYF103Z25
C926	ELECTR. CAPACITOR	CEAS101M16
C927	CERAMIC CAPACITOR	CCDSL470J50
C928	ELECTR. CAPACITOR	CEAS470M10
C929	AXIAL CERAMIC CAPACITOR	CKPUYF103Z25
C930	ELECTR. CAPACITOR	CEAS101M16
C931	AXIAL CERAMIC CAPACITOR	CKPUYF223Z25

Mark No.	Description	Parts No.
C932-935	CERAMIC CAPACITOR	CKDYF223Z50
C936	ELECTR. CAPACITOR	CEAS4R7M50
C937	CERAMIC CAPACITOR	CKDYF223Z50
C938	ELECTR. CAPACITOR	CEAS010M50
C939	CERAMIC CAPACITOR	CCDSL271J50
C940	CERAMIC CAPACITOR	CKDYB222K50
C941	CERAMIC CAPACITOR	CKDYF473Z50
C942	ELECTR. CAPACITOR	CEAS2R2M50
C943	ELECTR. CAPACITOR	CEAS470M10
C944	ELECTR. CAPACITOR	CEAS0R1M50
C945	ELECTR. CAPACITOR	CEANP2R2M50
C946	ELECTR. CAPACITOR	CEAS470M16
C947	CERAMIC CAPACITOR	CKDYF473Z50
C948	CAPACITOR (470p)	ACE1039
C949	ELECTROLYTIC CAPACIT	CEAS1R5M50
C950	ELECTR. CAPACITOR	CEAS3R3M50
C951	ELECTR. CAPACITOR	CEAS470M10
C952, 953	CERAMIC CAPACITOR	CKDYB122K50
C955	ELECTR. CAPACITOR	CEASR22M50
C956	CERAMIC CAPACITOR	CKDYB122K50
C957, 958	ELECTR. CAPACITOR	CEAS2R2M50
C959	AXIAL CERAMIC CAPACITOR	CKPUYF223Z25
C960	ELECTR. CAPACITOR	CEAS0R1M50
C961, 962	CERAMIC CAPACITOR	CKDYB272K50
C963	ELECTR. CAPACITOR	CEAS2R2M50
C964	CERAMIC CAPACITOR	CKPUYB101K50
C965	CERAMIC CAPACITOR	CKPUYB102K50
C967	ELECTR. CAPACITOR	CEAS101M16
RESISTORS		
VR901	VR (10k)	ACP-105
VR902	VR (20k)	ACP1004
VR903	VR (5.0k)	ACP1015
	Other resistors	RD1/8PM□□□□
OTHERS		
CN10	CONNECTOR (10P)	KPE10
X901	CRYSTAL RESONATOR	ASS1042
X902	CERAMIC RESONATOR	ATF1027
	ANTENNA TERMINAL	AKA1010
	4-P	
	AM RF TUNING BLOCK	AXX1026
	2 SERIAL F.E. MODULE ASSEMBLY	AXQ1002
◎ VOLUME ASSEMBLY (AWZ3941)		
SEMICONDUCTORS		
IC5001	MECHANISM DRIVER IC	TA7291S
IC5002	OP-AMP IC	RC4558DXP

Mark No.	Description	Parts No.
CAPACITORS		
C5001, 5002	ELECTR. CAPACITOR	CEAS2R2M50
C5003, 5004	ELECTR. CAPACITOR	CEAS4R7M50
C5005-5008	CHIP CAPACITOR	CKSQYB393K50
C5009, 5010	ELECTR. CAPACITOR	CEAS100M25
C5012	CERAMIC CAPACITOR	CKCYF473Z50

Mark No.	Description	Parts No.
RESISTORS		
VR5001	VARIABLE RESISTOR (100k)	ACX1068
	Other resistors	RS1/10S□□□J

● HEADPHONE ASSEMBLY (AWZ3942)

Mark No.	Description	Parts No.
CAPACITORS		
C599	CERAMIC CAPACITOR	CKCYX473M25

Mark No.	Description	Parts No.
RESISTORS		
R523, 524	METAL OXIDE RESISTOR	RS1LMF331J
R599	CARBONFILM RESISTOR	RD1/8PM100J

Mark No.	Description	Parts No.
OTHERS		
CN	JACK (HEADPHONE)	AKN1028

● FRONT ASSEMBLY (AWZ3950)

Mark No.	Description	Parts No.
SEMICONDUCTORS		
IC1001-1003	OP-AMP IC	RC4558DXP
IC2001, 2002	OP-AMP IC	RC4558DXP
IC3001	CONTROL MCU	PDG078A
Q2001, 2002	TRANSISTOR	2SC2878
Q2003	TRANSISTOR	XDA143ES
Q3001	TRANSISTOR	XDC143ES
Q3002	TRANSISTOR	2SC2458
D1001-1005	DIODE	1SS252
D3001-3003	DIODE	1SS252
D3005	ZENER DIODE	RD6.2ESB
D3009-3017	DIODE	1SS252

Mark No.	Description	Parts No.
SWITCHES		
S3001-3009	SWITCH (POWER, TIMER SET, WAKE UP/-, FM MONO, TUNER-, SFC BGM, SMART MEMORY, SFC CLEAR,,S.STEREO WIDE)	ASG1034
S3011-3018	SWITCH (DISPLAY, REC TIMER/+, FREQ/ST, TUNER+, SFC DISCO, SMART START/SET, FUNCTION CD, FUNCTION TUNER)	ASG1034

Mark No.	Description	Parts No.
S3020-3025	SWITCH (CLOCK ADJUST, MEMORY, BAND, SFC HALL, FUNCTION PHONO, FUNCTION TAPE)	ASG1034

Mark No.	Description	Parts No.
COIL		
L3001	AXIAL INDUCTOR	LAU220K

Mark No.	Description	Parts No.
CAPACITORS		
C1001, 1002	CERAMIC CAPACITOR	CKSQYB471K50
C1003, 1004	CERAMIC CAPACITOR	CKSQYB152K50
C1005, 1006	CERAMIC CAPACITOR	CKSQYB472K50
C1007, 1008	CERAMIC CAPACITOR	CKSQYB153K50
C1009-1015	CERAMIC CAPACITOR	CKSQYF473Z50

C2001, 2002	CERAMIC CAPACITOR	CKSQYB153K50
C2003, 2004	CERAMIC CAPACITOR	CKDYX823M16
C2005, 2006	CERAMIC CAPACITOR	CKSQYB332K50
C2007, 2008	CERAMIC CAPACITOR	CKSQYB153K50
C2009, 2010	ELECTR. CAPACITOR	CEJA2R2M50

C3001	CERAMIC CAPACITOR	CKSQYF473Z50
C3002	ELECTR. CAPACITOR	CEJA010M50
C3003	ELECTR. CAPACITOR	CEJA470M10
C3004	ELECTROLYTIC CAPACIT	CEAS010M50

C3006, 3007	CERAMIC CAPACITOR	CKSQYF473Z50
-------------	-------------------	--------------

C3008	CHIP CAPACITOR	CKSQYB102K50
C3009	ELECTR. CAPACITOR	CEAS471M10
C3010-3012	CERAMIC CAPACITOR	CKSQYF473Z50
C3100	CAPACITOR (0.047/5.5)	ACH1135

Mark No.	Description	Parts No.
RESISTORS		
VR2001	VARIABLE (100k- x 2)	ACS1107
VR2002	VARIABLE (100k- x 2)	ACS1107
R1003, 1004	CARBONFILM RESISTOR	RD1/8PM104J
R3020-3025	CARBONFILM RESISTOR	RD1/8PM563J
R3028	CARBONFILM RESISTOR	RD1/8PM103J
R3029	CARBONFILM RESISTOR	RD1/8PM101J
R3032-3024	CARBONFILM RESISTOR	RD1/8PM223J
R3035	CARBONFILM RESISTOR	RD1/8PM103J
R3036-3041	CARBONFILM RESISTOR	RD1/8PM222J

Other resistors	RS1/10S□□□J
-----------------	-------------

Mark No.	Description	Parts No.
OTHERS		
V3001	FL TUBE	AAV1142
X3002	CRYSTAL RESONATOR	ASS1015
CN3	30P SOCKET	AKP1095
	FL SPACER	AEB1196
	REMOTE RECEIVER UNIT	AXX1010

6. ADJUSTMENTS

- As to connections and points to be adjusted, refer to Fig. 6-1.
- Where an asterisk (*) is given for "level dB μ V", set to the level (dB μ V) at which the voltage is roughly half the voltage between TP904 and GND at 60dB.

6.1 FM TUNER ADJUSTMENT

- Set the BAND selector to "FM".
- Perform VCO adjustment two minutes or more after turning the power ON.

Note :
 Stereo modulation : Main 1kHz L+R \pm 68.25kHz dev.
 Pilot 19kHz \pm 6.75kHz dev.

Step No.	Adjustment title	FM SG (1kHz \pm 75kHz dev.)		Reception frequency display	Adjustment location	Specifications
		Frequency (MHz)	Level (dB μ V)			
1	Detector coil T-meter adjustment	98.0	80	98.0MHz	L907	Adjust so that the DC voltage between the TP901 and TP902 is 0 \pm 50mV.
2	VCO adjustment	98.0 Non modulation	80	98.0MHz	VR903	Adjust so that the frequency between TP905 and GND is 76 \pm 0.5kHz.
3	TUNED indicator sensitivity adjustment	98.0 (Stereo modulation)	18 (\pm 3dB)	98.0MHz	VR902	Adjust so that the indicator lights up.

6.2 AM TUNER ADJUSTMENT

- Set the BAND selector "AM".

Note : Adjustment marked with "※" is only for HEWZI.

Step No.	Adjustment title	AM SG (400Hz 30% Mod.)		Reception frequency display	Adjustment location	Specifications
		Frequency (kHz)	Level (dB μ V)			
1	Tracking adjustment ※	603	*	603kHz	MW block ANT coil	Adjust so that the DC voltage between TP904 and GND is maximum.
2		1395		1395kHz	TC901	
3		Repeat 1 and 2 above				
4	IFT adjustment ※	603	*	603kHz	F904	
5	TUNED indicator sensitivity adjustment	999	55 \pm 5	999kHz	VR901	

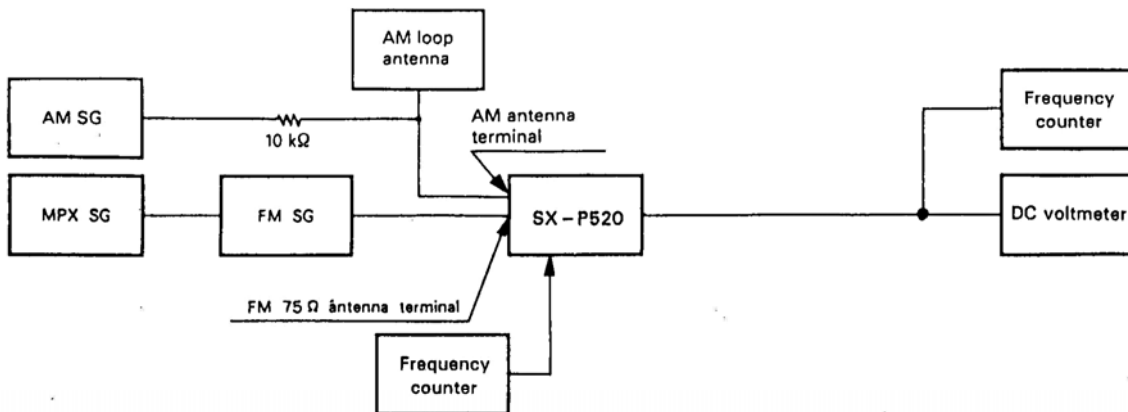

Fig. 6-1 FM and AM adjustment wiring diagram

7. IC INFORMATION

■ PDG078A (IC3001) : TUNER CONTROL MICRO-COMPUTER

● Pin Function

No.	Function Name	I/O	Description	ACTIVE
1	STEREO	I	STEREO Signal	L
2	REMOCON	I	REMOCON Signal	
3	TUNE	I	TUNE Signal	L
4	MONO	O	FM MONO Output	H
5	LOCAL	O	FM LOCAL Output	H
6	9k/10k	I	Switching Channel Step Frequency	H : 9k
7	POWER	O	POWER ON/OFF Switching	L
8	DISP CLK	I	CLOCK Input for CD display data communication.	
9	DISP DATA	I	DATA Input for CD display data communication.	
10	SP RELAY	O	Relay control for speaker.	L
11	VOL UP	O	Output for motor VR control IC (TA7291S).	H
12	VOL DOWN	O	Output for motor VR control IC (TA7291S).	H
13	NC	O	NC	
14	KEY IN1	I	Key Scan Input 1	H
15	KEY IN2	I	Key Scan Input 2	H
16	KEY IN3	I	Key Scan Input 3	H
17	S. CLK	O	CLOCK Output for system bus communication.	
18	S. DATA	I/O	DATA Input/Output for system bus communication.	
19	REQ/EN CD	I/O	CD Communication Request/Enable for system bus communication.	
20	REQ/EN DECK	I/O	DECK Communication Request/Enable for system bus communication.	
21	MUTE	O	LINE MUTE Control	H
22	VOL POSITION	I	NC	
23	BPF IN 1	I	A/D input (100Hz) for spectrum analyzer BPF	

No.	Function Name	I/O	Description	ACTIVE
24	BPF IN 2	I	A/D input (330Hz) for spectrum analyzer BPF	
25	BPF IN 3	I	A/D input (1kHz) for spectrum analyzer BPF	
26	BPF IN 4	I	A/D input (3.3kHz) for spectrum analyzer BPF	
27	BPF IN 5	I	A/D input (10kHz) for spectrum analyzer BPF	
28	MODEL A	I	Port A for switching destination L : HE, HB types H : HEWZI, KUC, SD, YPW types	
29	MODEL B	I	Port B for switching destination L : HEWZI type H : HE, HB, KUC, SD, YPW types	
30	RET		MICRO-COMPUTER RESET Input	L
31	EXTAL		Connected to ceramic oscillator (ASS1015) (8MHz).	
32	XTAL			
33	Vss	GND	Reference Voltage (GND)	
34	TREBLE 1	O	Control Output for SFC IC (PA0049)	
35	TREBLE 2	O		
36	BASS 1	O		
37	BASS 2	O		
38	WIDE 1	O		
39	WIDE 2	O		
40	AUDITION	O	AUDITION ON/OFF	H
41	MIC MUTE	O	Mic Mixing cancel (Playing ASES)	H
42	4052 INH	O	FUNCTION switching IC Control Output	
43	4052 B	O	FUNCTION switching IC Control Output	
44	4052 A	O	FUNCTION switching IC Control Output	
45	FL S1	O	FL Control Segment Output	

No.	Function Name	I/O	Description	ACTIVE
46	FL S2/KO9	O	FL Cotrol Segment Output/ Key Scan Strobe Output	
47	FL S3/KO8	O		
48	FL S4/KO7	O		
49	FL S5/KO6	O		
50	FL S6/KO5	O		
51	FL S7/KO4	O		
52	FL S8/KO3	O		
53	FL S9/KO2	O		
54	FL S10/KO1	O		
55	FL S11	O		FL Control Segment Output
56	FL S12	O		
57	FL S13	O		
58	FL S14	O		
59	FL S15	O		
60	FL 11G	O	FL Control Timing Output	
61	FL 10G	O		
62	FL 9G	O		
63	FL 8G	O		
64	FL 7G	O		
65	FL 6G	O		
66	FL 5G	O		
67	FL 4G	O		
68	FL 3G	O		
69	FL 2G	O		
70	FL 1G	O		

No.	Function Name	I/O	Description	ACTIVE
71	Vfdp	I	-30V FDP load power Input	
72	Vdd	I	+5V Power Supply Input	
73	NC	O	NC	
74	1067 STB	O	Chip enable for Port expander IC	H
75	PLL EC	O	Chip enable for Tuner PLL IC	H
76	PLL/1067 DATA	O	Data for Tuner PLL IC and Port expander IC	
77	PLL/1067 CLK	O	Clock for Tuner PLL IC and Port expander IC	
78	50/60Hz IN	I	AC pulse Input	
79	MODEL C	I	Port C for switching destination L : SINGLE CD H : TWIN/MULTI CD	
80	DISP CLK	I	CLOCK Input for CD display data communication	

8. FOR HB AND HEWZI TYPES

NOTES:

- Part without part number cannot be supplied.
- The Δ mark found on some component parts indicates the importance of the safety factor of the part. Therefore, when replacing, be sure to use parts of identical designation.
- Parts marked by "●" are not always kept in stock. Their delivery time may be longer than usual or they may be unavailable.

8.1 CONTRAST OF MISCELLANEOUS PARTS

SX – P520/HB, HEWZI and SX – P520/HE have the same construction except for the following :

Mark	Symbol & Description	Part No.			Remarks
		SX – P520/ HE type	SX – P520/ HB type	SX – P520/ HEWZI type	
●	POWER assembly	AWZ3944	AWZ3944	AWZ3945	
●	TRANS assembly	AWZ3930	AWZ3930	AWZ4239	
●	FRONT assembly	AWZ3950	AWZ3950	AWZ3951	
●	TUNER assembly	AWZ3938	AWZ3938	AWZ3939	
●	VOLUME assembly	AWZ3941	AWZ3941	AWZ3963	
●	HEADPHONE assembly	AWZ3942	AWZ3942	AWZ3943	
Δ	C1 Capacitor (0.01/AC400V)	ACG1003	
Δ	AC Power cord	ADG1049	ADG1087	ADG1012	
	Screw	ABA – 115	GND screw for C523, C524 and C526
	FM antenna	ADH1005	ADH1005	
	FM antenna assembly	ADH1002	
	Operating instructions (Dutch, Swedish, Spanish, Portuguese)	ARC1324	For RECEIVER
	Operating instructions (Dutch, Swedish, Spanish, Portuguese)	ARC1337	For CASSETTE, CD
	Operating instructions (English, French, German, Italian)	ARE1223	For RECEIVER
	Operating instructions (English, French, German, Italian)	ARE1233	For CASSETTE, CD
	Operating instructions (English)	ARB1362	For RECEIVER
	Operating instructions (English)	ARB1364	For CASSETTE, CD
	Operating instructions (German, Italian)	ARC1336	For RECEIVER
	Operating instructions (German, Italian)	ARC1340	For CASSETTE, CD

◎ POWER ASSEMBLY (AWZ3945)

POWER assembly (AWZ3945) and POWER assembly (AWZ3944) have the same construction except for the following :

Mark	Symbol & Description	Part No.		Remarks
		AWZ3944	AWZ3945	
	D601-D605 D712-D714, D716, D717	1SS252 1SS252	HSS104-02 HSS104-02	
	L501, L502 L503, L504	ATH-133	ATH-059 ATH-059	
	C103, C104, C108 C107 C151, C152, C155-C157, C160, C171, C172 C153	CCCSL101J50 CCDSL101J50	CKCYB391K50 CKCYB391K50 CKCYB471K50	
	C154 C158, C159, C161, C162 C163, C164 C165, C166 C503, C504 CKCYB331K50	CCCSL470J50 CCDSL470J50 CKDYB471K50 CCCSL101J50 CKCYB391K50	
	C518, C519 C521, C522, C526 C523, C524 C703 (0.01μF/AC250V) C703 ACG1005	CKCYF103Z50 CCDSL101J50 CKDYB102K50 CQMA473K250	
	C713	CEAS470M63	CEAS470M100	
	R121, R122, R501, R502 R151, R152 R153, R154 R155-R158	RD1/8PM102J	RD1/8PM222J RD1/8PM221J RD1/8PM471J RD1/8PM101J	

◎ TRANS ASSEMBLY (AWZ4239)

TRANS assembly (AWZ4239) and TRANS assembly (AWZ3930) have the same construction except for the following :

Mark	Symbol & Description	Part No.		Remarks
		AWZ3930	AWZ4239	
	C11, C12	CQMXA473J100	

● FRONT ASSEMBLY (AWZ3951)

FRONT assembly (AWZ3951) and FRONT assembly (AWZ3950) have the same construction except for the following :

Mark	Symbol & Description	Part No.		Remarks
		AWZ3950	AWZ3951	
	D1001-D1005	1SS252	HSS104-02	
	D3001-D3003	1SS252	HSS104-02	
	D3009-D3017	1SS252	HSS104-02	

● VOLUME ASSEMBLY (AWZ3963)

VOLUME assembly (AWZ3963) and VOLUME assembly (AWZ3941) have the same construction except for the following :

Mark	Symbol & Description	Part No.		Remarks
		AWZ3941	AWZ3963	
	C5013, C5014	CCSQSL101J50	

● HEADPHONE ASSEMBLY (AWZ3943)

HEADPHONE assembly (AWZ3943) and HEADPHONE assembly (AWZ3942) have the same construction except for the following :

Mark	Symbol & Description	Part No.		Remarks
		AWZ3942	AWZ3943	
	C551, C552	CCCSL101J50	

● **TUNER ASSEMBLY (AWZ3939)**

TUNER assembly (AWZ3939) and TUNER assembly (AWZ3938) have the same construction except for the following :

Mark	Symbol & Description	Part No.		Remarks
		AWZ3938	AWZ3939	
	Q903, Q904, Q915, Q916 Q906	RN1203 RN2201	
	D906, D907	HSS104-02	
	L901 L906	LAU2R2M LAU330K	
	TC901 C908 C915 C921 C952, C953 CKDYF223Z50 CKPUYF473Z16 CKDYB122K50 ACM-018 CKPUYF223Z25 CKDYB102K50	
	C961, C962 C969 C970	CKDYB272K50	CKDYB392K50 CCDCH270J50 CCDCH101J50	
	R911, R914, R919 R915, R917 R924 R925 R955 R959, R960	RD1/8PM103J RD1/8PM102J RD1/8PM331J RD1/8PM152J RD1/8PM392J RD1/8PM561J RD1/8PM221J RD1/8PM122J RD1/8PM682J	
	2 Serial F.E. module assembly 4 Serial F.E. module assembly 4P antenna terminal with PAL 2P antenna terminal with PAL AM RF Tuning block	AXQ1002 AKA1010 AXX1026 AXQ1004 AKA1012 AXX1027	

NOTE :
PCB connection diagram for HEWZI type, refer to page 11.

8.2 SCHEMATIC DIAGRAM (TUNER assembly : For HEWZI type)

A

B

C

D

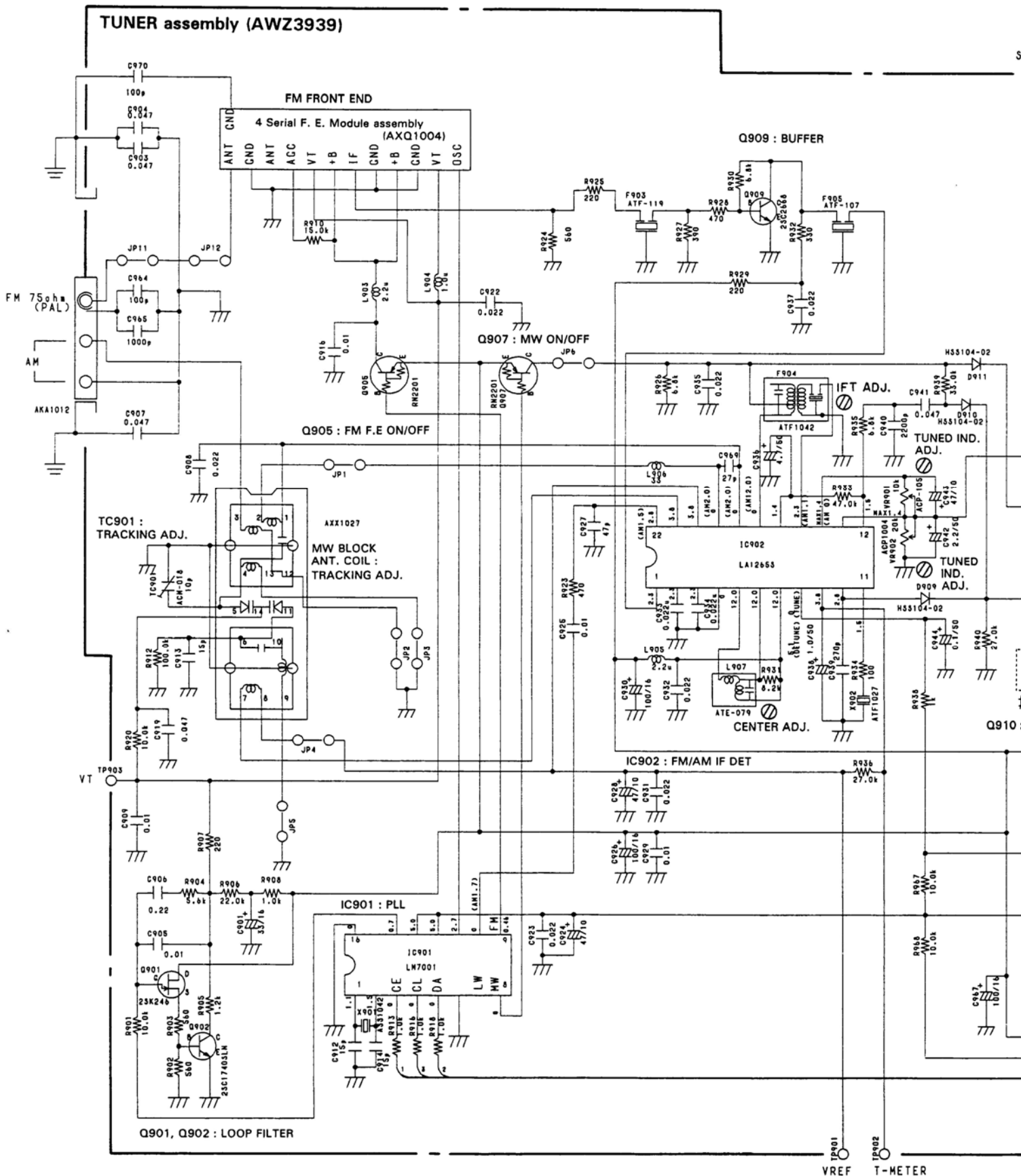

9. PANEL FACILITIES

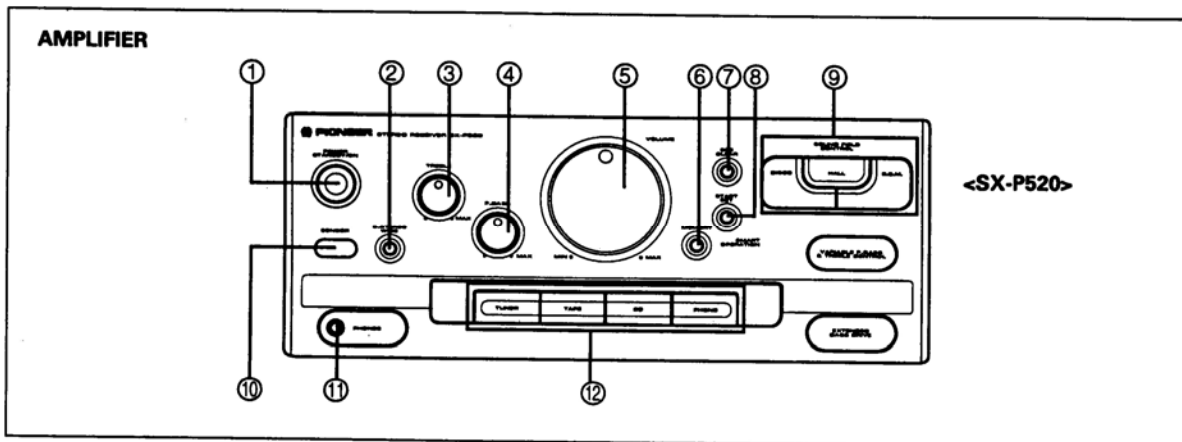

AMPLIFIER

① POWER STANDBY/ON switch

This is the switch for electric power.

ON: When set to the ON position, power is supplied and the unit becomes operational.

STANDBY: When set to the STANDBY position, the main power flow is cut and the unit is no longer fully operational. A minute flow of power feeds the unit to maintain operation readiness. (The display shows only the time.)

② S.STEREO WIDE button

③ TREBLE button (SX-P420)

TREBLE control(SX-P520)

④ P.BASS control

⑤ VOLUME control

⑥ SMART OPERATION MEMORY button

⑦ SFC CLEAR button

⑧ SMART OPERATION START/SET button

⑨ SOUND FIELD CONTROL buttons (DISCO, HALL, B.G.M.)

⑩ Remote sensor window (SENSOR)

⑪ Headphones jack (PHONES)

⑫ Input selector buttons (TUNER/TAPE/CD/PHONO)

Auto Function

This model is equipped with "Auto Function" operation, so when the switch for CD PLAY, RANDOM, PLAY (tape), +/- (tuner up/down) or BAND is pressed, the function switches automatically. Use the PHONO function button to select the component connected to the PHONO jacks, since Auto Function is not effective for this.

NOTE:

The function cannot be switched during recording except for tape copying. (Auto Function does not operate either.)

Demo Function

To enter the demo mode, press SFC CLEAR when power is STANDBY. The power is automatically turned on. In the demo mode, various functions of this system appear on the display. When a program source is selected, you can enjoy listening to the selected source simultaneously.

To cancel demo mode:

Press any buttons of the amplifier or remote control unit.

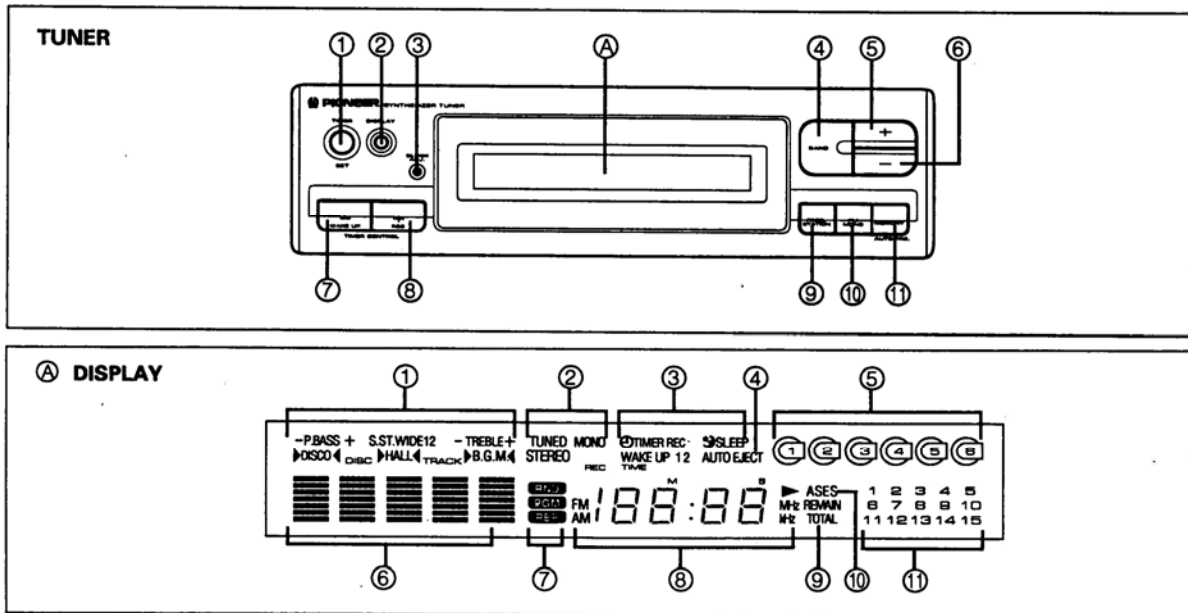

TUNER

- ① **TIMER SET** button
- ② **DISPLAY** button
- ③ **CLOCK ADJ.** button
- Ⓐ **Display**
- ④ **BAND** button
- ⑤ **+** (tuner up) button
- ⑥ **-** (tuner down) button
- ⑦ **TIMER CONTROL WAKE UP/-** button
- ⑧ **TIMER CONTROL REC/+** button
- ⑨ **FREQ./STATION** button
- ⑩ **FM MONO** button
- ⑪ **AUTO PRE. MEMORY** button

Ⓐ DISPLAY

- ① **Sound field control indicators**
Display the SOUND FIELD CONTROL settings.
- ② **Tuner indicators**
Indicate the tuning mode.
- ③ **Timer indicators**
Display timer settings.
- ④ **AUTO EJECT indicator (For PDC-P520T)**
Lights when AUTO EJECT function is ON.
- ⑤ **Disc number indicators (For PDC-P520M and PDC-P520T (No.1 and No. 2 only))**
- ⑥ **Function display**
Normally functions as a spectrum analyzer.
Also, this displays the selected function. In the TUNER mode, this displays the station No., and when playing a CD it displays the track No.
- ⑦ **RND:** Lights during random play for CD player.
PGM: Lights during program input and program play for CD player.
REP: Lights during repeat play for CD player.
- ⑧ **Frequency/Time display**
In TUNER mode, frequency is displayed. In any other mode it displays the time.
- ⑨ **REMAIN/TOTAL indicator (For CD player)**
In CD mode, "REMAIN" shows the remaining play time and "TOTAL" shows the total play time.
- ⑩ **ASES (Auto Synchro Editing System) indicator**
Lights when A.S.E.S. is performed.
- ⑪ **Music calendar (For CD player)**

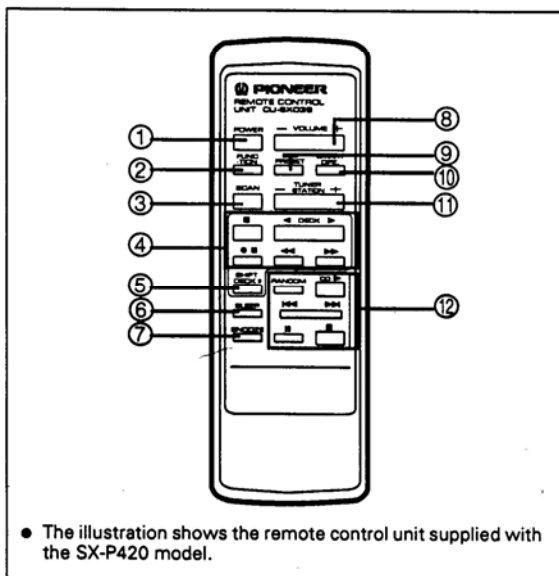

REMOTE CONTROL UNIT

- ① **POWER button**
- ② **FUNCTION button**
Each time this button is pressed, the function changes in the following sequence: TUNER → TAPE → CD → PHONO → TUNER.
- ③ **SCAN button**
In TUNER mode: This button is used for scanning preset stations.
In CD mode: This button is used for Hi-Lite Scan.
- ④ **DECK I/II operation buttons**
(◀ ▶ Play, ■ Stop, ◀◀ ▶▶ Fast, ● II Rec pause)
- ⑤ **SHIFT DECK II button**
To operate Deck II, press the desired deck operation button while pressing this button.
- ⑥ **SLEEP button**
- ⑦ **SNOOZE button**
- ⑧ **VOLUME +/- button**
- ⑨ **SFC PRESET button**
Each time this button is pressed, the SOUND FIELD CONTROL setting changes in the following sequence: DISCO → HALL → B.G.M. → SFC clear.
- ⑩ **SMART OPE. button**
- ⑪ **TUNER STATION +/- button**
- ⑫ **CD operation buttons**
(▶ Play, ■ Stop, II Pause, ◀◀ ▶▶ Track search, RANDOM (For SX-P420/PDC-P420), DISC (For SX-P520/PDC-P520T and PDC-P520M))